

KÖSTER

Engineering works and foundry

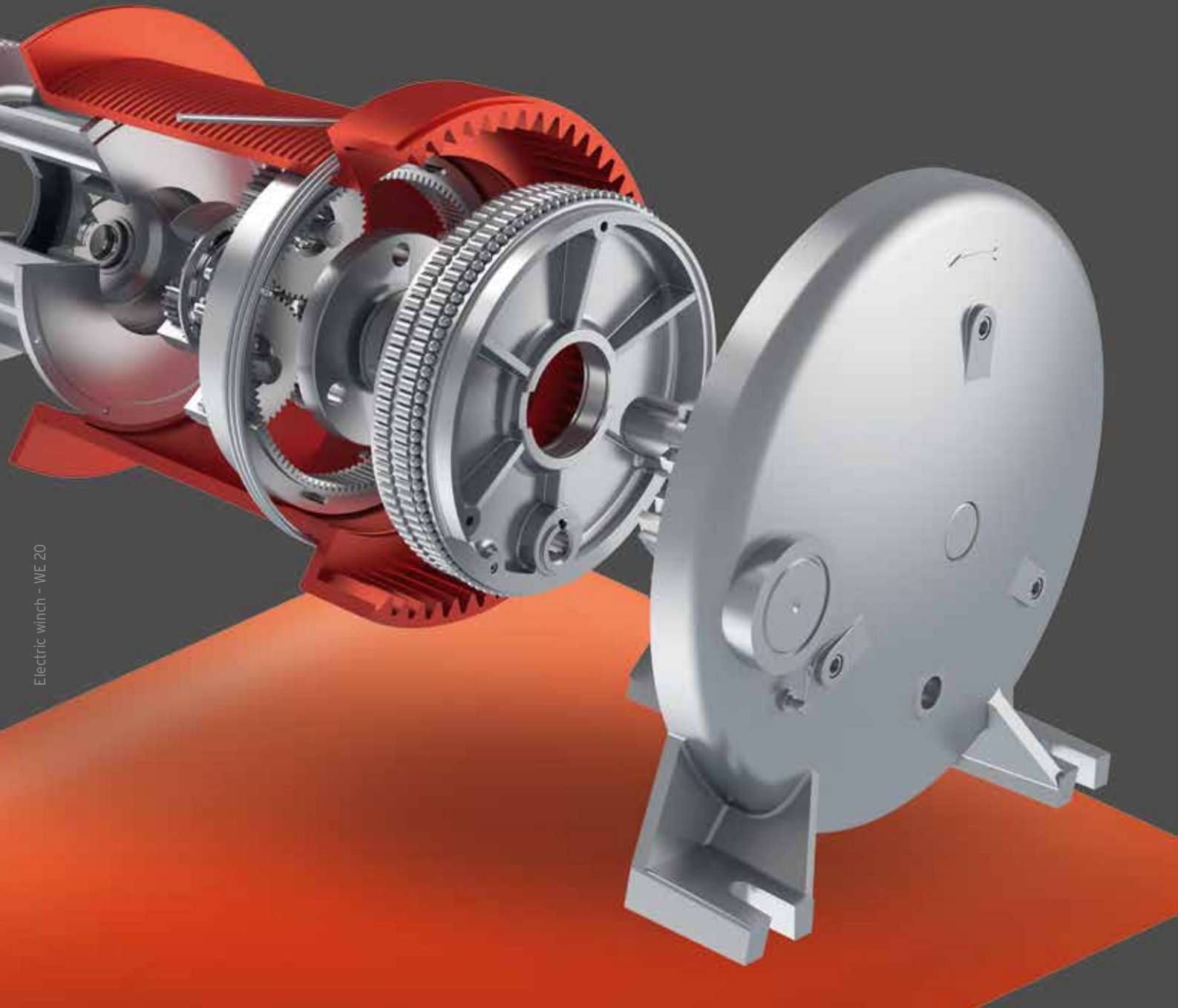

Electric winch - WE 20

Winches

●●● **KÖSTER - Our Products**
 customized - durable - low-maintenance



| | | | | |
|--|---|--|--|---|
| Pumps | Winches | Swimming pool technology | Swimming pool technology | Steel hydraulic construction |
| Axial and mixed flow pumps for water and aqueous media | Manual and electric winches for lifting and moving all kind of loads | Wave generators, mechanically or pneumatically driven | Steel and sheet metal machining | Flood gates Overflow weirs Flood barriers |
| Capacity from 100 l/s to 8.000 l/s | Special requirements - | For public and private pools and spas, professional training pools, research institutions and zoos | iron casting, modular graphite casting, SiMo and cast steel | Gate valves (round up to DN 1800) |
| Delivery height from 1 m up to 30 m | Special areas of application | Lift floors for multipurpose and therapy pools, pool partitions counter stream systems | Customized parts or product lines, assemblies or complete systems | Backflow traps (round up to DN 2000) |
| Materials and design to customers demands, up to the pump impeller | Customised design - Compact construction | | Cast cleanly and machined ready for assembly | Made to order - using materials such as steel, stainless steel, cast iron and wood |

●●● **Picture Credits**

Legend (P=Page; l=left; r=right; a=above; c=centre; b=below; f=from). www.soenke-dwenger.de - P2 fl, P9 lc, P20, P21, P51, P52, P54, P55; Adam Mørk - P8 r; OWP Butendiek - P9 la; Town Hall Gallery Leverkusen - P9 rc; ROS KAVANAGH PHOTOGRAPHER - P9 lb, P26; BEUMER Group - P9 ra; zentilia - Fotolia.com - P42.; http://www.nordnordwest.com Thorsten Bosse - S25 ru, S41 ro.

➔ **Winches**
Products & Services

- 04 A company with history
- 06 Reliability & Safety
- 08 References & Projects

10 Electric winches

- 12 Standard range of products
- 17 Transport of persons
- 18 Enhanced protection classes - maritime use
- 20 Protection class - Controller - Electronics
- 22 Application varieties

24 Special Solutions

- 25 Stage and entertainment
- 29 Reel winch - raise, lower, load
- 30 Extreme environmental conditions
- 31 Integrated package solutions

32 Manual winches

- 34 Standard range of products
- 40 Stage and entertainment
- 42 Maritime and offshore use

44 Accessories

- 45 Pulleys
- 51 Other accessories

52 KÖSTER Service

- 53 Delivery & Assembly
- 54 Maintenance & Repair
- 55 Spare Parts

Dimensional deviations within manufacturing tolerances as well as technical modifications are subject to change. Further technical information on request.

→ A company with history Innovation based on tradition

150 Years of experience - familiar and cosmopolitan

KÖSTER GmbH & Co. KG was founded in 1861 under the name Maschinenfabrik und Eisengießerei J. M. Voss.

The company has been family-owned for seven generations and lends direct credibility to values such as continuity, tradition consciousness, adaptability, innovative spirit and flexibility.

In the course of its history, KÖSTER has successfully managed to adapt its product range to - sometimes drastic - changes in the market and to market their products worldwide.

Inspirations for the present - with focus on the future

In the beginning, agricultural machinery such as ploughs, land rollers, straw cutters and threshing machines were produced. When the general energy consumption increased with industrialization, KÖSTER started developing wind engines for fixed power generation installations, which were also used for irrigation and drainage of low-lying land. In the course of electrification, it became increasingly difficult to sell wind turbines. KÖSTER responded by developing propeller pumps for irrigation and drainage, deep well and tapered propeller pumps, and dredging boats. KÖSTER has patented many of their designs. In the segment of cable winches KÖSTER first designed and manufactured hoisting winches for hay, grain and flour, as well as elevators for construction sites. The Adler electric winch, also patented later, evolved from the manual winch. Until now, with its range of products, KÖSTER has been particularly known for seeking, finding and supplying customized solutions for the most diverse applications.



Fixed wind engine for generating electricity - Innovation by KÖSTER in the age of industrialization



KÖSTER - Milestones from 1861 until today

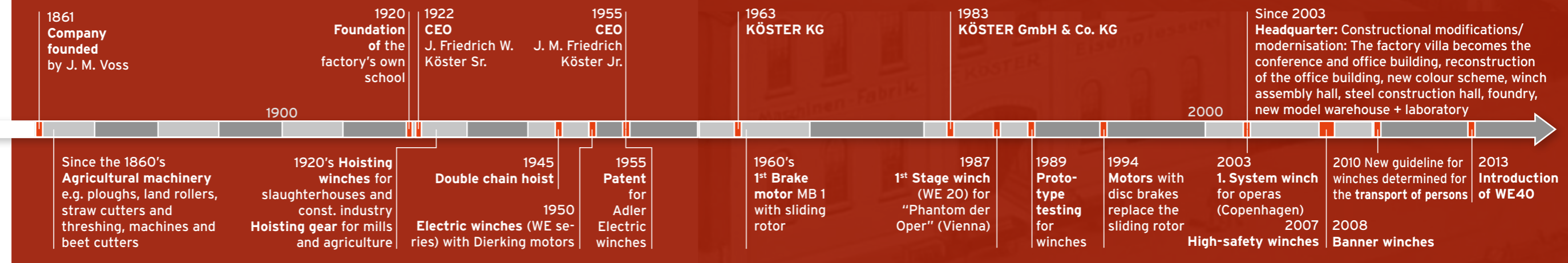

➔ **Reliability & Safety**
in product lines

Continuity and flexibility - the key to success

KÖSTER looks back at over 150 years of corporate history and has, in the meantime, been a family-run business managed by seven generations. These figures speak for the continuity of our company and its experience. Moreover, this includes a high degree of adaptability which enables KÖSTER to face the conditions prevailing in the market to accept its changes and to implement them in the form of positive developments. KÖSTER and its products represent these traditional values.

Our corporate principles are confirmed by our customers' satisfaction and loyalty.

Special solutions are our standard

The development of the current design of KÖSTER winches goes back to originally specially developed products. Today, our manual and electric winches set the market standard.

Winches made by KÖSTER are traditionally sold under the brand name of Adler. They are the outcome of ingenious technology and know-how that undergoes continuous improvement and perfection.

KÖSTER winches offer a comprehensive range of applications and compatible solutions for diverse applications. They are light-weight and safe to handle. They are characterized by optimally coordinated movements for all types of loads and hence, they run very silently. Our winches are also insensitive to environmental influences to a large extent.

First-class workmanship in conjunction with high-quality mechanics and its typically robust design ensure the above-average service life of a KÖSTER winch, which calls for low maintenance.

KÖSTER winches are built in such a manner that production processes get interrupted at the respective place of deployment only under exceptional circumstances by unscheduled maintenance work.

Each winch supplied is subject to a 100% quality control. That is tested safety - as a standard.

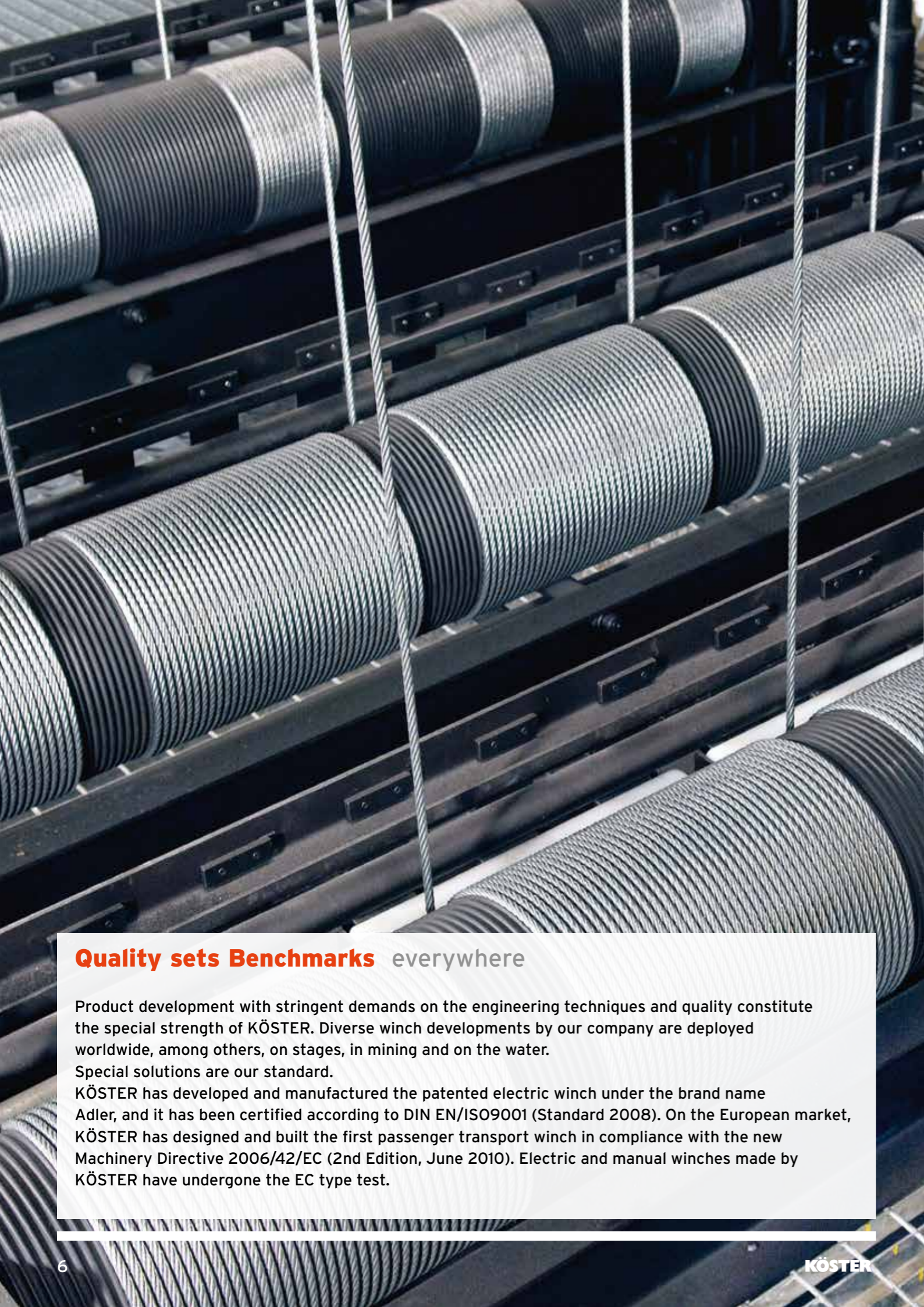

Above:
Head Office of KÖSTER -
The office building with a
view of the new foundry

At left:
Fly towers over the stage
in Musikhuset Esbjerg -
the hoists to move the
scenery run over KÖSTER
cable winches

Quality sets Benchmarks everywhere

Product development with stringent demands on the engineering techniques and quality constitute the special strength of KÖSTER. Diverse winch developments by our company are deployed worldwide, among others, on stages, in mining and on the water.

Special solutions are our standard.

KÖSTER has developed and manufactured the patented electric winch under the brand name Adler, and it has been certified according to DIN EN/ISO9001 (Standard 2008). On the European market, KÖSTER has designed and built the first passenger transport winch in compliance with the new Machinery Directive 2006/42/EC (2nd Edition, June 2010). Electric and manual winches made by KÖSTER have undergone the EC type test.

➔ **References & Projects**
satisfied customers, worldwide

Winch equipment made by KÖSTER - deployed worldwide

The following reference projects bear impressive testimony to the various application areas of our cable winches. At the same time, they are proof of our global field of activities.



2008 Erfurt railway station
Winch for advertising banner



2003 Royal Opera Copenhagen
Stage equipment



2004 Antwerp port
Ship-loading equipment



2015 Offshore wind farm Butendiek
Manual winch made of stainless steel



2003 Musikhuset Esbjerg
Rigging system for stage decoration



2013 Steel industry, Duisburg
Transport of persons



2009 Hannoversch-Münden
Slipway system



2009 Town hall gallery, Leverkusen
Decorative rotunda, remote-controlled



2010 Grand Canal Theatre Dublin
Stage equipment

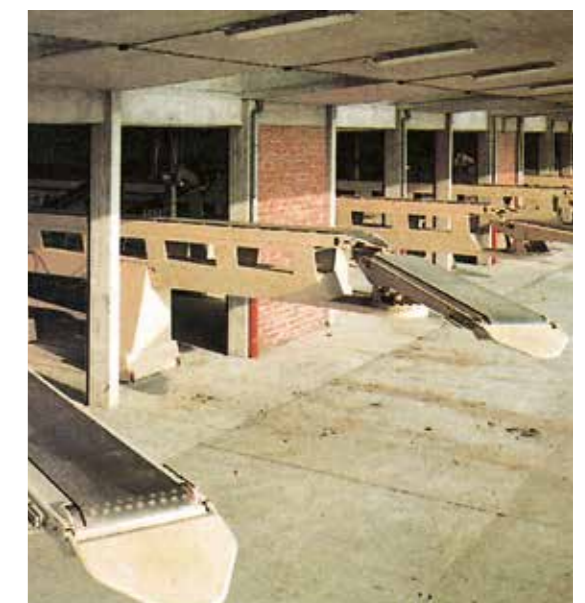

1970 Loading terminal
with eight loading ramps

| | | |
|-------------|---|---------|
| 1.01 | Standard range of products | Page 12 |
| 1.02 | Passenger transport | Page 17 |
| 1.03 | Enhanced protection classes for offshore use | Page 18 |
| 1.04 | Protection class - Controller - Electronics | Page 20 |
| 1.05 | Application variants | Page 22 |



WE series
The starting point
for KÖSTER winch
designs

1.0 Electric Winches

A robust standard remains flexible

KÖSTER electric winches as a standard product are characterized by compact construction and encasing of the entire drive. We claim the most stringent demands on our electric winches. As a result, you get the reliability that the name of KÖSTER stands for.

With the diverse range of supplementary fittings we can supply almost any kind of adaptation to meet the needs of the customers. This is the KÖSTER philosophy and makes meeting client requirements our primary task.

Standard

- > Mechanism group 2_m (M5)
- > Protection class IP 54
- > with in-built controller
- > Hoist limiting

Additional Options

- > Protection classes IP 55, IP 56 or IP 65
- > Customized drum grooving
- > Extended cable drum - up to 3,000 mm
- > Enlarged drum flange wheel for accommodating greater cable size or length
- > Secondary cable fastening for moving loads back and forth
- > Travelling hoists as electric winch
- > Spare manual drive
- > Brake ventilation
- > Pulling in the horizontal direction with free-spinning drum (Shunting winch)
- > Automatic shut-down in case of slack cable
- > with cable winding mechanism
- > with cable pressing roller

WE Series - An inside view

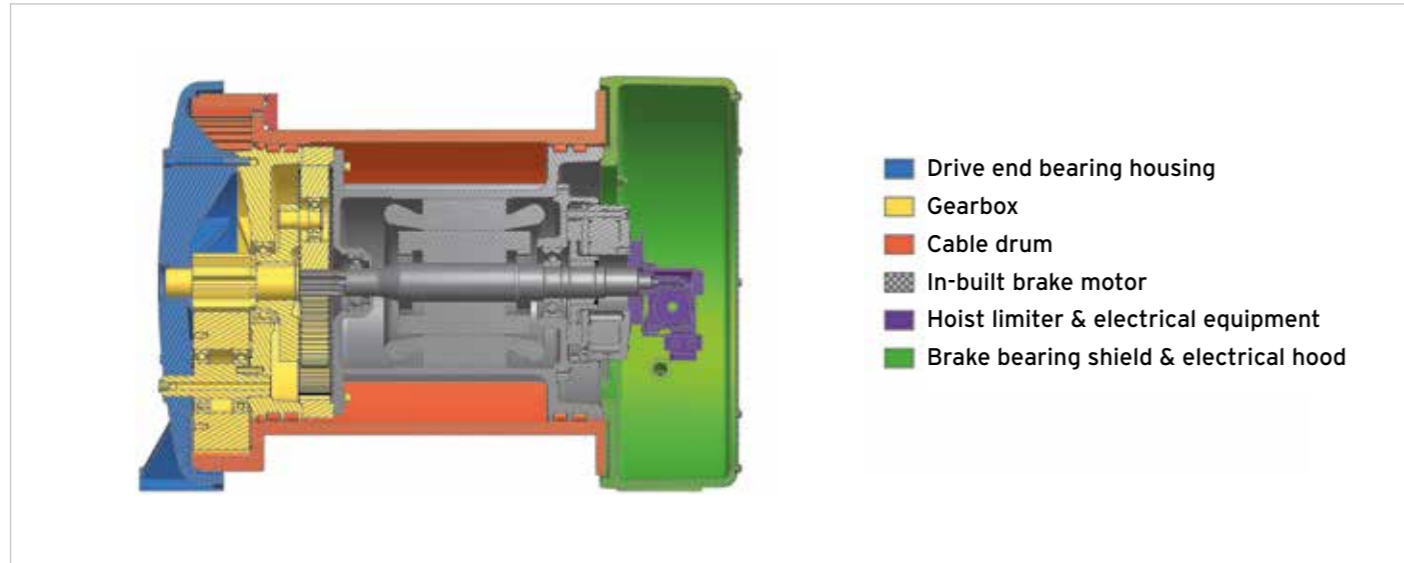

Electric winches - External dimensions

| Maß ¹⁾ | WE 1 | WE 5 | WE 10 | WE 20 | WE 40 |
|-------------------|------|------|-------|-------|-------|
| a | 355 | 435 | 572 | 720 | |
| b | 220 | 270 | 360 | 460 | |
| c | 17 | 25 | 30 | 33 | |
| d | 203 | 257 | 330 | 430 | |
| d ₁ | 254 | 325 | 437 | 540 | |
| e | 401 | 485 | 648 | 804 | |
| f | 275 | 338 | 443 | 556 | |
| g | 277 | 350 | 468 | 590 | |
| h | 141 | 178 | 238 | 298 | |
| k ¹⁾ | 452 | 524 | 692 | 861 | |
| l | 234 | 274 | 365 | 475 | |
| m | 60 | 72 | 102 | 120 | |
| n | 55 | 68 | 83 | 96 | |
| o | 249 | 275 | 327 | 446 | |
| p | 280 | 353 | 472 | 593 | |
| q | 203 | 249 | 335 | 415 | |
| s ²⁾ | M 12 | M 16 | M 20 | M 24 | |
| v | 51 | 39 | 44 | 57 | |
| w | 23 | 25 | 38 | 38 | |
| x | 18 | 27 | 28 | 32 | |
| z | 26 | 40 | 51 | 57 | |

Our standard WE winch, of which there are currently four different sizes, is the nucleus of all KÖSTER projects in the electric winch area.

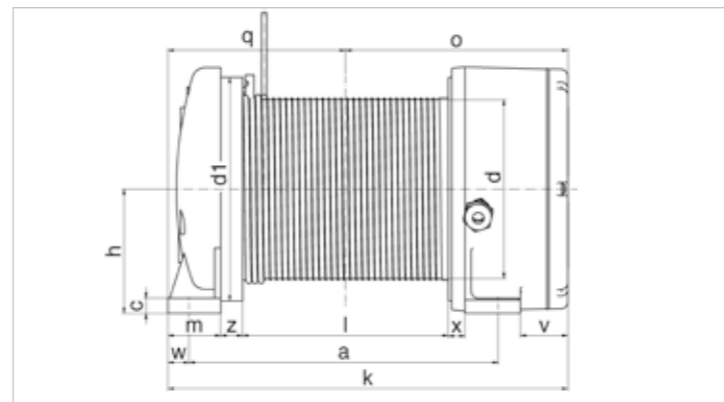
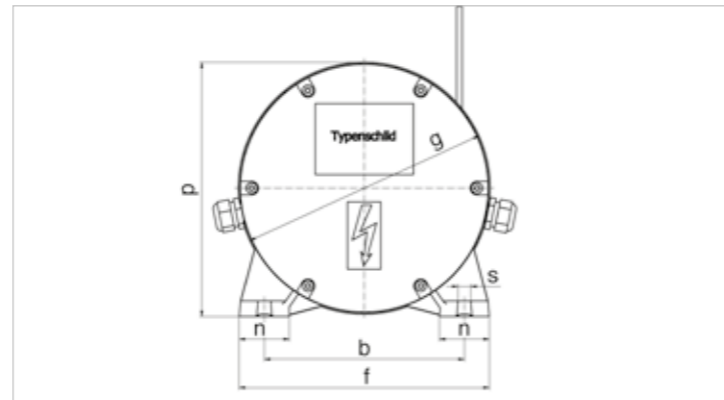

1) The minimum dimensions and the size depending on the scope of the electrical equipment and the double brake in accordance with BGV C1
2) Open elongated hole for fastening screw

Multi-layer cable roll

With cable pulley enlargement

| Maß ¹⁾ | WE 1 | WE 5 | WE 10 | WE 20 | WE 40 |
|-------------------|--------|--------|--------|--------|-------|
| A1 / B1 | 278/0 | 350/0 | 470/0 | 590/0 | |
| A2 / B2 | 320/20 | 400/25 | 530/30 | 650/30 | |
| A3 / B3 | 350/35 | 450/50 | 600/65 | 700/55 | |

1) Size a - cf. Table page 14, A1 - A3 Flanged pulley diameter, B1 - B3 Minimum lining of the winch supports

Cable remains single-layered in the groove

With cable pressure roller

Cable coiled multi-layered, remains in the groove

With cable spooler

| With a long drum | | | | | | |
|--------------------|--------|--------|----------|----------|----------|-------------|
| Size ¹⁾ | WE 1 L | WE 5 L | WE 1 Lx | WE 5 Lx | WE 10 Lx | WE 20/40 Lx |
| a | 561 | 601 | L+121 | L+161 | L+207 | L+245 |
| d | 203 | 257 | 215 | 266 | 350 | 450 |
| e | 607 | 651 | L+167 | L+211 | L+283 | L+329 |
| k ²⁾ | 658 | 690 | L+218 | L+250 | L+327 | L+386 |
| l | 440 | 440 | 360-3000 | 400-3000 | 500-3000 | 700-3000 |

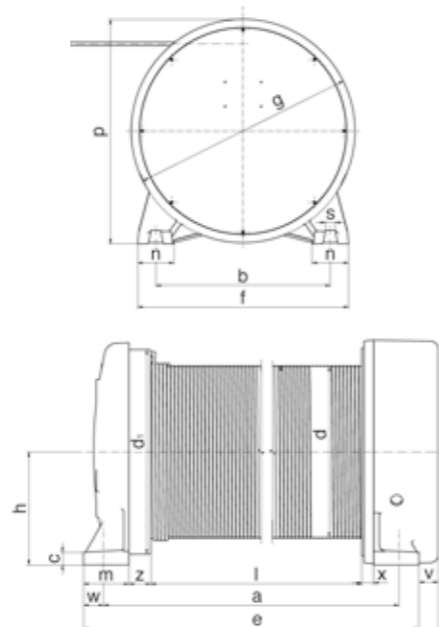

1) For other sizes cf. Table 1) Size a -cf. Table page 14

2) Minimum dimensions and size depend on the scope of the electric equipment or the second automatic mechanical brake according to BGV C1

1.02 Transport of Persons

Electric winches that are meant for transporting people are subject to very stringent technical safety regulations as stipulated in the Machinery Directive in its currently applicable version.

KÖSTER winches that are deployed for man riding take these special safety standards into account and are equipped either with a spare manual drive or emergency stop control. They also have an additional safety brake. For most of the projects that have been implemented by KÖSTER so far in the segment of transporting persons, an EC prototype test certificate is available.

E 30 Winch for rescuing people

Winches can be installed on indoor cranes. They are often used in incinerators basically for rescuing people or for occasional maintenance work.

| Rescuing people | E 30 / E 20 P | |
|-------------------------|---------------|---------------------|
| Driving mechanism group | - | 2 _m (M5) |
| Bearing loads | kg | 3000 |
| Passenger load | kg | 1500 |
| Cable speed | m/min. | 0..20 |
| Number of cables | - | 2 |
| Cable diameter | mm | 12 |
| Cable layers | - | 1 |
| Cable capacity | m | 45 |

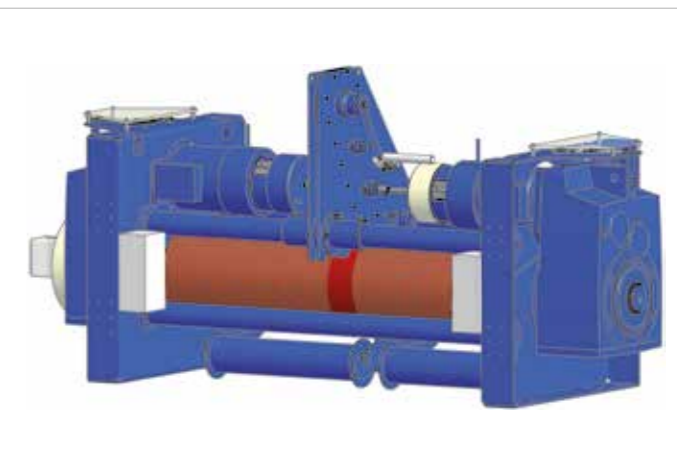

E 630 P Winch for passenger transport

Winches for travelling through pipes and shafts, among others, in hydro-electric power stations are equipped with a passenger cage, an emergency brake and a failsafe PLC controller.

| Maintenance work | E 630 P | |
|-------------------------|---------|---------------------|
| Driving mechanism group | - | 2 _m (M5) |
| Passenger load | kg | 630 |
| Cable speed | m/min. | 3.6 / 18 |
| Number of cables | - | 2 |
| Cable diameter | mm | 8 |
| Cable layers | - | 1 |
| Cable capacity | m | 140 |

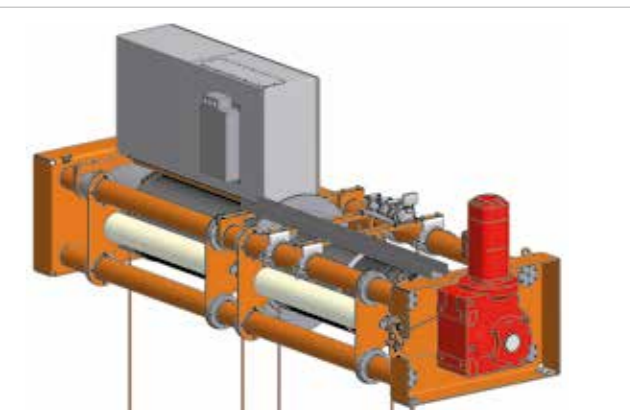

1.03 Enhanced protection classes - for offshore use

Low elevation for heavy loads

- > Maintenance-free
- > Standard design with IP 65 class of protection (protection against ingress of dust and water jet)
- > In-built brake motor in "F" class insulation material (for higher ambient temperature and up to 100 % humidity)
- > Robust conical brakes with asbestos-free friction linings
- > Gears run in an oil bath with ball bearing (high level of efficiency)
- > Extremely low-noise operation (approx. 70 dB (A)) owing to helical gears
- > Special design possible for single-cable operation, which reduces load forces

| Enhanced protection class | | SHW 10/4 (Standard) |
|---------------------------------------|----------|-----------------------|
| Load / Cable pulling force (2 cables) | kg (daN) | 995 |
| Lifting speed | m/min. | 7 |
| (Max.) cable elevation | m | 5.0 |
| Wire cable diameter | mm | 2 x 7 |
| Standard cable length | m | 25 |
| Motor power at 40% ED | kW | 1.3 |
| 3-phase operating voltage | | 3x400 V, 50 Hz |
| AC control voltage | | 230 V, 50 Hz |
| Weight | kg | 95 |
| Driving mechanism group (DIN 15020) | | 1 A _m (M4) |

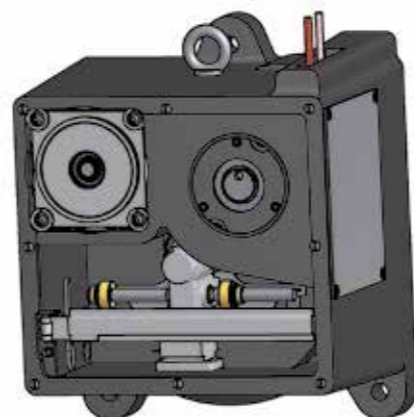
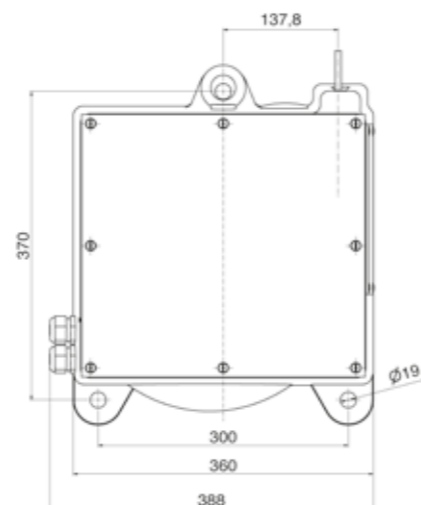

Short stroke with drive safety

Electric winches with spare manual drives can raise and lower loads independently of the power supply. These electric winches are used accordingly in situations where reliable winch operation has to be guaranteed, even in the event of power failure.

With manual operation in versions WE 1 H / WE 5 H, the electric motor is decoupled and manual operation is coupled in at the same time.

With models WE 10 H and WE 20 H the manual drive is attached at the motor side: This does not mean that the motor is decoupled, but that the brake of the built-in brake motor is released. The load pressure brake of the manual drive holds the load, and the stroke limitation that is installed there prevents the end points from being travelled over manually.

| Standard design, driving mechanism group 2 _m (M5) | | | | | | |
|--|--------|--------------------------|----------------------|----------------------------|--|--------|
| | Design | Load ¹⁾ kg | Cable-speed m/min | Load el. per rev. mm | Crank pressure at rated load (kg) ²⁾ | |
| | | | | | 275 mm | 460 mm |
| WE 1 H | 10/2 | 100 | 36 | - | - | - |
| | 10/4 | 160 | 18 | - | - | - |
| | 10/6 | 160 | 12 | - | - | - |
| | 10/8 | 160 | 9 | - | - | - |
| | 20/2 | 180 | 20 | - | - | - |
| | 20/4 | 250 | 10 | - | - | - |
| | 20/6 | 250 | 6 | - | - | - |
| WE 5 H | 10/4 | 500 | 18 | 85 | 30 | 17.9 |
| | 10/6 | 500 | 12 | 85 | 30 | 17.9 |
| | 10/8 | 500 | 9 | 85 | 30 | 17.9 |
| | 20/4 | 250 | 34 | 85 | 15.6 | - |
| | 20/6 | 250 | 22 | 85 | 15.6 | - |
| | 20/8 | 250 | 17 | 85 | 15.6 | - |
| | 50/4 | 630 | 4.5 | 85 | 37.3 | 22.3 |
| | 50/6 | 630 | 3 | 85 | 37.3 | 22.3 |
| | 60/4 | 380 | 8 | 85 | 23.1 | 13.8 |
| | 60/6 | 380 | 5.5 | 85 | 23.1 | 13.8 |
| WE 10 H | 10/4 | 1000 | 18 | 26.3 | 20.5 | - |
| | 10/6 | 1000 | 12 | 26.3 | 20.5 | - |
| | 10/8 | 1000 | 9 | 26.3 | 20.5 | - |
| | 20/4 | 750 | 27 | 38.1 | 22.1 | - |
| | 20/6 | 750 | 18 | 38.1 | 22.1 | - |
| | 20/8 | 750 | 13.5 | 38.1 | 22.1 | - |
| | 30/4 | 500 | 36 | 49.3 | 19.3 | - |
| | 50/4 | 1250 | 4.5 | 12.8 | 13 | - |
| | 50/6 | 1250 | 3 | 12.8 | 13 | - |
| | 60/4 | 1000 | 6.3 | 18.5 | 14.8 | - |
| WE 20 H | 60/6 | 1000 | 4 | 18.5 | 14.8 | - |
| | 50/4 | 2500 | 4.5 | 7 | 20 | - |
| | 50/6 | 2500 | 3 | 7 | 20 | - |
| | 60/4 | 1800 | 7 | 11 | 19 | - |
| | 60/6 | 1800 | 4.5 | 11 | 19 | - |
| | 70/4 | 1400 | 9 | 14 | 20 | - |
| 70/6 | 1400 | 6 | 14 | 20 | - | |

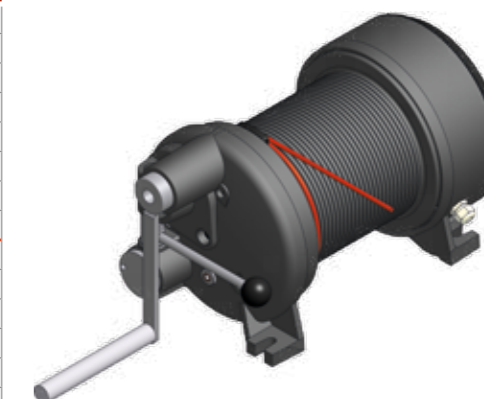

1) Related to the lower cable layer respectively

2) With an extended crank arm the winch supports must have linings

1.04 Protection classes - Controllers - Electronics

Safely adapted

The permissible temperature range and the effect of the media, some of which are aggressive (moisture or water, vapours, acids, alkalis, oil and fuel) represent usage restrictions that have to be taken into consideration in the design of the winches.

Depending on the type of use, they must also be protected from penetration by foreign bodies such as dust, contamination e.g. by bacteria or viruses (medical engineering) and the effect of shocks. Many projects that have already been realised by KÖSTER prove that we can implement electronic solutions that are adapted to any application.

Protection classes - for housings and motors

KÖSTER electric winches are manufactured with protection class IP 54 in accordance with DIN 40050 as standard.

If required by the intended usage, we can also manufacture our winches with higher protection classes of IP 55, IP 56 and IP 65.



Controllers

The standard versions of KÖSTER electric winches are controlled using reversing contactors and main contactors, from the starting point of the normal control voltage 230 volts AC, 50 Hz.

Different protection voltages can be implemented using additional control transformers.

A KÖSTER electric winch can also be supplied without a controller.



Motor protection - from simple to special

Our motors are supplied with insulation class „F“ as standard. The built-in braked motors are designed for 100% relative humidity and an ambient temperature of up to +60°C.

The motor of a KÖSTER electric winch is always protected by a lockable **switch with a magnetic quick-action release**. On request we will also install emergency stop switches, signal lamps, shunt opening releases and additional auxiliary switches.

If electric winches are intended for varying deployment locations (so-called installation winches) the **motor protection switch** is directly on the winch itself.

Our WE 1 to WE 20 electric winches are equipped with **thermal motor winding protection** as standard, and therefore reliably protected up to the overload limit under load.

We also implement **cold conductor temperature sensors**, the most effective and reliable protection device for electric motors at present. For the relevant control unit we use thermistor full protection relays with automatic resetting,

self-monitoring and LED fault indicators. The built-in braked motors are equipped with twisted cold conductors if necessary.

Our **electronic overload protection** continuously measures the motor output during operation and reliably switches the electric winch off immediately in the event of overloading. The motors of electric winches that are used outdoors are prone to corrosion. In this case we install braked motors with **stationary heating**.

The brake system for our motors for WE 1 to WE 10 and WE 20 in version 50/4 is designed in such a way that it automatically adapts to operating

voltage changes. Operating voltages with a three-phase current of between 200 and 690 volts, 50/60 Hz can be supplied.

The motor for WE 20 in versions 10/4 to 20/8 is equipped with a multi-disk brake for a brake connecting voltage of 400 volts with an Si one-way rectifier, with 168 volts of direct current at the brake coil. Motors with different operating voltages are available. The transformer rectifier that reduces the direct current at the brake coil to 24 volts.

1.05 Application varieties

Versatile

KÖSTER electric winches can be deployed in diverse ways. We have or can find the most compatible product for almost any requirement.

- > Large or small loads
- > Raising or lowering
- > Pulling and pushing
- > Setting down precisely
- > Transport of persons
- > Resistant to extreme environmental stress

You know your requirements. We exactly build the overall compatible solution or develop the required cable winch for integration in your project.

We build and manufacture reliable solutions for the following requirement profiles (and in combinations, too):

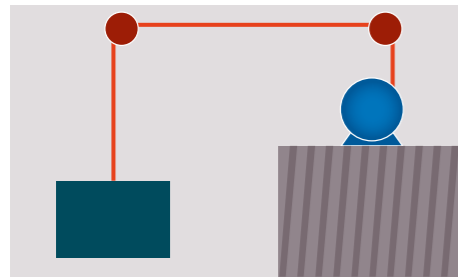

Normal design

Functional design, robust and useful at the same time, very wide performance range for lifting height and cable speed, and a hoist limiter can be installed.

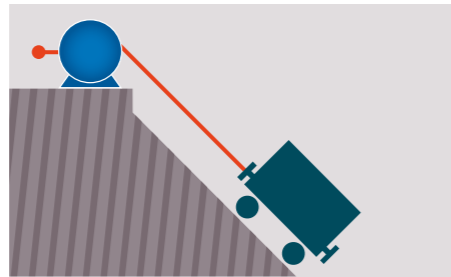

Raising and lowering with safety

With brake release equipment and spare manual drive, loads can be moved if needed, even in case of power failure, inclined or cargo lifts can be guided in rails.

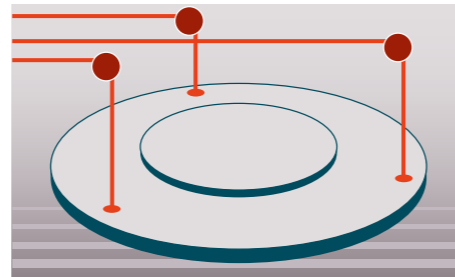

Hoisting heavy components

Single-cable or multi-cable grooved winch drums with additional cable fasteners for hoisting covers, bellows or other heavy or bulky components using multi-cable operation.

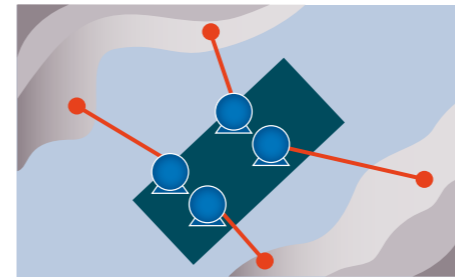

Moving large weights

With enlarged flanged pulleys for large cable capacity. Developed for moving e.g. pump dredges, ferries, ships or similar loads.

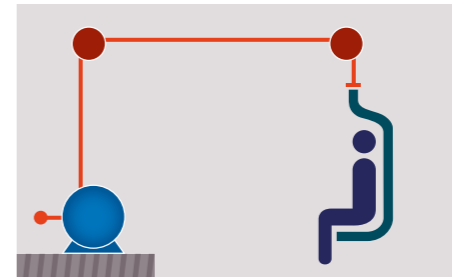

Transporting people

Winch with spare manual drive, single or dual cable drum, and for large lifting heights, provided additionally with cable winding mechanism. Used e.g. in silo entry systems.

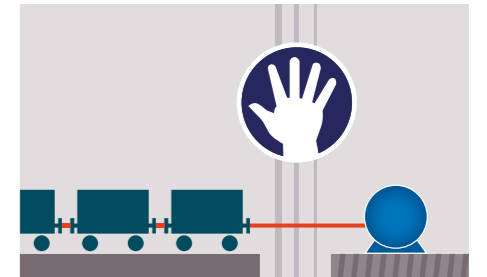

Shunting

Winch where the free spinning of the drum can be enabled, and the cable can be pulled easily by hand. Deployment as a shunting winch for moving lorries, wagons or similar loads on even routes.

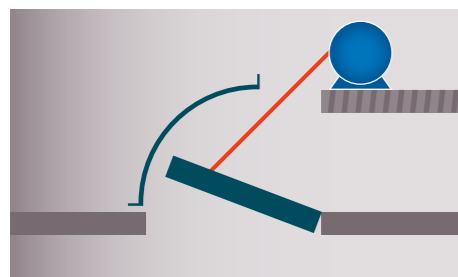

Reliably specified closing force

Electronic overload protection by fast-acting relay, and thus, application of a specific value of closing force by the winch (valves, gates or similar).

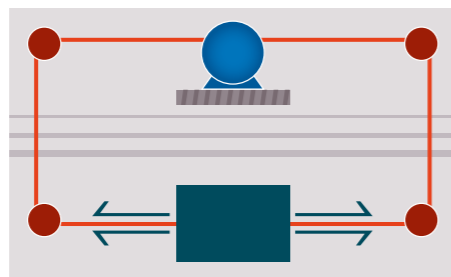

Moving loads back and forth

Single-cable grooved drum with second cable fastening at the flanged pulley on the opposite side. Robust, low-maintenance and practical.

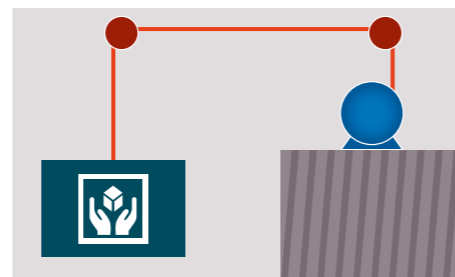

Setting down loads precisely

Separately installed frequency converter, prevents jerks on start-up, starting-up/braking with low speed (short-term positioning); enables loads to be set down accurately and gently.

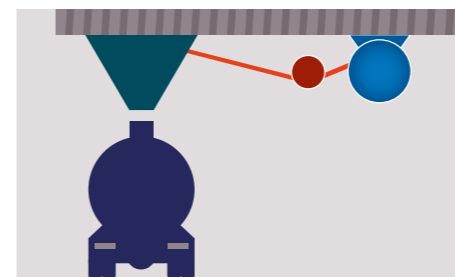

Loading loose bulk material

With slack cable switch that automatically shuts off the winch after putting down the load. Used for loading by loading equipment and a nozzle that can be lowered.

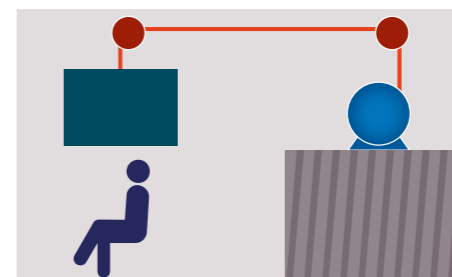

Persons under suspended loads

Winches with dual braking system for deployment in theatres, malls and other public buildings.

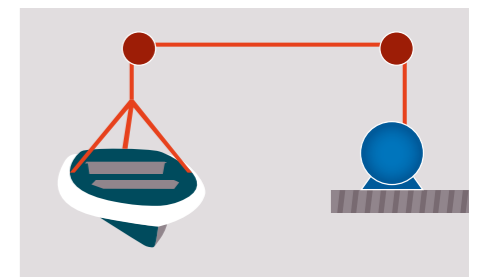

Extreme environmental conditions

Winches with enhanced protection class for deployment in zones that are exposed to extreme temperatures.

Silo entry seat for passenger transport (Study)

| Passenger transport | | E 300 P |
|-------------------------------------|--------|---------|
| Load for passenger transport | kg | 300 |
| Load for silo transport | kg | 150 |
| Cable lift | m | 50 |
| Lifting speed | m/min. | max. 18 |
| Load elevation per crank revolution | mm | 80 |
| Cable diameter | mm | 8 |
| Drum diameter | mm | 270 |
| Drum length per cable | mm | 193 |
| Number of cables | - | 2 |
| Number of cable layers | - | 3 |
| Driving power | kW | 0.9 |

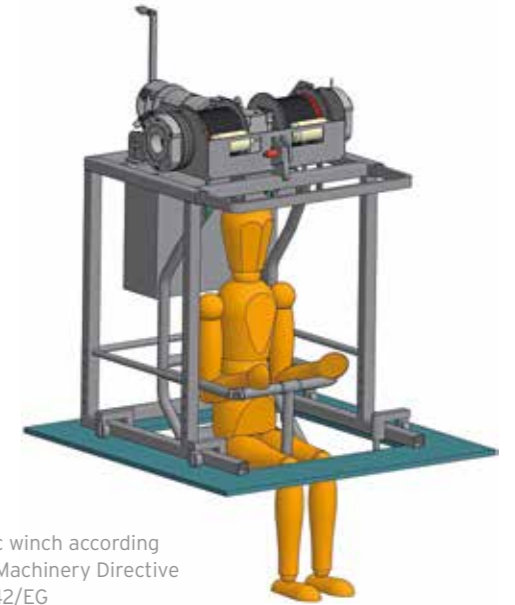

Electric winch according to the Machinery Directive 2006/42/EG



H 250 B - modular point hoist winch with extremely compact design

| | | |
|-------------|---|----------------|
| 2.01 | Stage and entertainment | Page 25 |
| 2.02 | Reel winch - raise, lower, load | Page 29 |
| 2.03 | Extreme environmental conditions | Page 30 |
| 2.04 | Integrated package solutions | Page 31 |

2.0 Special Solutions

It all starts with the cable

The standard winches made by KÖSTER already cover a very wide spectrum of potential areas of application.

Moreover, there are requirements concerning conditions beyond those of the standard regarding the loads specified, the desired cable speed or certain environmental conditions and accordingly, for which special solutions need to be found.

The core competence of KÖSTER lies in developing a customized product for every conceivable application.

The cable strength is determined from the given load and lifting requirements. The selection of the drum size and all other winch components is based on this. In principle, a KÖSTER winch is constructed in close cooperation with the customer and with the comprehensive knowledge of the existing framework conditions pertaining to the requirements so that it finally works optimally under these conditions.

2.01 Stage and entertainment

Media winch

This module point hoist winch has an extremely compact design. Its vertical arrangement makes it possible to vary the height of the drums.

| Media winch | | H 250 B |
|-------------------------|-------|----------|
| Load | kg | 250 |
| Cable speed | m/min | 12 |
| Cable hoisting distance | m | 6 |
| Drum length | mm | variable |
| Number of cables | - | 4 |





Modern stage technology for light, sound and movement

A performance will be successful if all of the movements on stage are perfectly coordinated. Extremely heavy loads are sometimes suspended above the actors' heads. Unlimited safety and flexible control systems - the big stages of the world put their trust in winch technology from **KÖSTER**.

KÖSTER is a specialist in the development and production of winches and accessories for public areas in which persons are standing beneath heavy loads. Experience and competence in the planning and manufacture of stage winches are the guarantee of safety and long-term functionality.

Safety

- > Limit switch limitation
- > Overload monitoring
- > Wound in single layer
- > Protective sheet metal panelling
- > Independent dual brake system in accordance with BGV C1

Lightweight, mobile and cost-effective. The new media winch.

Our H 250 B media winch impresses with its compact design, ease of handling and quick and easy installation. The scenery is moved simultaneously using four winches with amazing cable control, using a battery-powered drive and, in another stage of expansion, with the electric drive. The H 250 B media winch has a modular design, and can therefore be adapted to practically any customer requirement in an uncomplicated and above all cost-effective way.

This makes this mobile, lightweight media winch extremely interesting to small theatres, theatre clubs and schools.

Stage winch

This point hoist winch in accordance with BGV C1 is equipped with electronic overload protection and a rope push-on device. It is exclusively supplied with a grooved rope drum.

Banner winch

Cable winches with vertical cable run for static loads up to 100 kg with storm safety up to 1000 kg. They are primarily used for hanging advertising banners in public buildings (according to BGV C1) and partial public areas (wind loads).



| Stage winch | WE 1 B to WE 20 B | |
|----------------|-------------------|-------------|
| Load | kg | 100-1,600 |
| Cable speed | m/min | 2.7 - 36 |
| Cable diameter | mm | 5 - 16 |
| Cable capacity | m | 19.4 - 38.6 |

| Banner winch | | E 100 B |
|-------------------------|--------|---------------------|
| Driving mechanism group | - | 2 _m (M5) |
| Load | kg | 100 |
| Cable speed | m/min. | 6 |
| Number of cables | - | 2 |
| Cable diameter | mm | 5 |
| Cable layers | - | 1 |
| Cable hoisting distance | m | 15 |

1) Version with frequency inverter recommended from rope speed of 30 m/min.
 2) The information relates to low-torsion cables with a steel inlay in accordance with DIN 3069.
 3) Two spare turns have already been deducted from this value in each case.

| Winches in accordance with BGV C1 | | | | | | | |
|-----------------------------------|--------|-----------------|--------------------------------------|---------------------------|-----------------------|---------------------------------------|-----------------------------|
| | Design | Load and speeds | | | Single cable capacity | | |
| | | Load kg | Speed (V) ¹⁾ m/min. | Power (P/ED) kW / % | Speed rpm | Cable diameter ²⁾ mm | Standard ³⁾ m |
| WE 1 B | 10/2 | 100 | 36.0 | 0.75 / 40 | 3000 | 5 | 23.0 |
| | 10/4 | 160 | 18.0 | 0.55 / 40 | 1500 | 6 | 19.4 |
| | 10/6 | 160 | 12.0 | 0.37 / 40 | 1000 | 6 | 19.4 |
| | 10/8 | 160 | 9.0 | 0.27 / 40 | 750 | 6 | 19.4 |
| | 20/2 | 225 | 20.0 | 0.75 / 40 | 3000 | 6 | 19.4 |
| | 20/4 | 225 | 10.0 | 0.55 / 40 | 1500 | 6 | 19.4 |
| | 20/6 | 225 | 6.0 | 0.37 / 40 | 1000 | 6 | 19.4 |
| | 20/8 | 225 | 5.0 | 0.27 / 40 | 750 | 6 | 19.4 |
| WE 5 B | 20/4 | 230 | 34.0 | 1.90 / 40 | 1500 | 6 | 29.2 |
| | 20/6 | 230 | 22.0 | 1.23 / 40 | 1000 | 6 | 29.2 |
| | 20/8 | 230 | 17.0 | 0.90 / 40 | 750 | 6 | 29.2 |
| | 60/4 | 230 | 8.0 | 0.66 / 40 | 1500 | 6 | 29.2 |
| | 60/6 | 230 | 5.5 | 0.44 / 40 | 1000 | 6 | 29.2 |
| | 10/4 | 450 | 18.0 | 1.90 / 40 | 1500 | 9 | 19.8 |
| | 10/6 | 450 | 12.0 | 1.23 / 40 | 1000 | 9 | 19.8 |
| | 10/8 | 450 | 9.0 | 0.90 / 40 | 750 | 9 | 19.8 |
| WE 10 B | 50/4 | 450 | 4.2 | 0.66 / 40 | 1500 | 9 | 19.8 |
| | 50/6 | 450 | 2.7 | 0.44 / 40 | 1000 | 9 | 19.8 |
| | 30/4 | 500 | 36.0 | 3.90 / 40 | 1500 | 9 | 34.9 |
| | 20/4 | 645 | 27.0 | 3.90 / 40 | 1500 | 10 | 31.5 |
| | 20/6 | 645 | 18.0 | 2.50 / 40 | 1000 | 10 | 31.5 |
| | 20/8 | 645 | 13.5 | 1.80 / 40 | 750 | 10 | 31.5 |
| | 60/4 | 645 | 6.3 | 1.90 / 40 | 1500 | 10 | 31.5 |
| | 60/6 | 645 | 4.0 | 1.23 / 40 | 1000 | 10 | 31.5 |
| WE 20 B | 10/4 | 930 | 18.0 | 3.90 / 40 | 1500 | 12 | 25.2 |
| | 10/6 | 930 | 12.0 | 2.50 / 40 | 1000 | 12 | 25.2 |
| | 10/8 | 930 | 9.0 | 1.80 / 40 | 750 | 12 | 25.2 |
| | 50/4 | 930 | 4.5 | 1.32 / 40 | 1500 | 12 | 25.2 |
| | 50/6 | 930 | 3.0 | 1.23 / 40 | 1000 | 12 | 25.2 |
| | 20/4 | 1200 | 32.0 | 8.00 / 40 | 1500 | 14 | 38.6 |
| | 20/6 | 1200 | 22.0 | 6.10 / 40 | 1000 | 14 | 38.6 |
| | 20/8 | 1200 | 16.0 | 4.30 / 40 | 750 | 14 | 38.6 |
| WE 20 B | 10/4 | 1600 | 21.0 | 8.00 / 40 | 1500 | 16 | 31.8 |
| | 10/6 | 1600 | 14.0 | 6.10 / 40 | 1000 | 16 | 31.8 |
| | 10/8 | 1600 | 10.5 | 4.30 / 40 | 750 | 16 | 31.8 |
| | 10/12 | 1600 | 7.0 | 2.90 / 40 | 500 | 16 | 31.8 |
| | 50/4 | 1600 | 4.5 | 1.90 / 40 | 1500 | 16 | 31.8 |
| | 50/6 | 1600 | 3.0 | 1.23 / 40 | 1000 | 16 | 31.8 |

1) It is recommended to use a frequency converter for speeds above 30 m/min.
 2) The cable diameter is with respect to rotation-resistant cables with steel inserts according to DIN 3069.
 3) While specifying the cable capacity, 2 spare loops have already been deducted.

2.02 Reel winch - raise, lower, load

Ideal for loading trucks and ships

This KÖSTER winch is suitable for raising and lowering loads of all kinds. The arrangement of the reels is oriented to the respective application. Its properties make it particularly suitable for use in HGV and maritime loading equipment.

The E 240 reel is fully enclosed and manufactured in protection class IP 55, which makes it essentially insensitive to environmental influences. The slack cable switch with individual shut-off (gearbox switch) is included in the accessories of this loading winch. By customer request we will deliver the relevant controller separately in the switch cabinet.

| Reel winch | | |
|--------------------|--------------------|---------------------|
| | | E 240 |
| Load capacity | kg | 240 |
| Cable lift | m | 1,6 |
| Cable speed | m/min ¹ | 5,2-6,8 |
| Number of cables | | 3 |
| Cable diameter | mm | 5 |
| Driving gear group | | 2 _m (M5) |
| Cable layers | | 5 |
| Type of protection | | IP 55 |

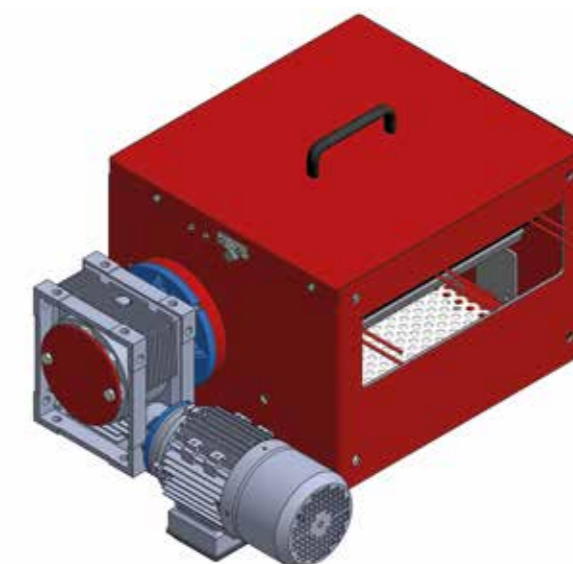
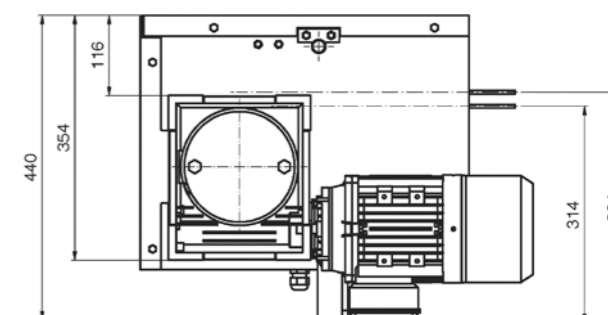

2.03 Extreme environmental conditions

Polar region

Special winches for raising and lowering, in this case, a sensitive sensor up to a depth of 3,000 m in the water designed for temperatures up to -45°C.

| Extremely low temperatures | | E 30 |
|----------------------------|--------|---------------------|
| Driving mechanism group | - | 2 _m (M5) |
| Load | kg | 300 |
| Cable speed | m/min. | 0 ... 20 ... 60 |
| Number of cables | - | 1 |
| Cable diameter | mm | 4 |
| Cable layers | - | 29 |
| Cable hoisting distance | m | 3000 |

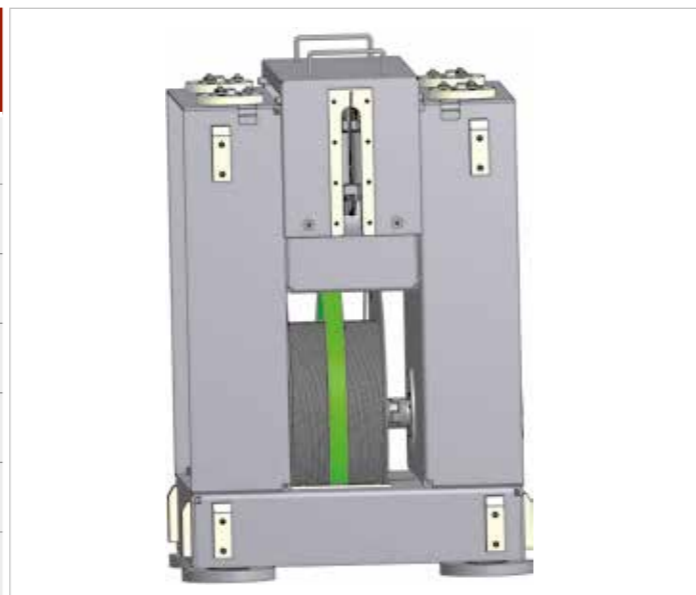

Desert region

Running wagons, designed for weather conditions like sand storms, increased atmospheric salt content and extreme temperature fluctuations between day and night, are hauled between two winches with walk drives on rails.

| Extreme temperature variations | | E 10 |
|--------------------------------|--------|---------------------|
| Driving mechanism group | - | 2 _m (M5) |
| Load | kg | 1250 |
| Cable speed | m/min. | 25 |
| Number of cables | - | 1 |
| Cable diameter | mm | 12 |
| Cable layers | - | 1 |
| Cable capacity | m | 70 |

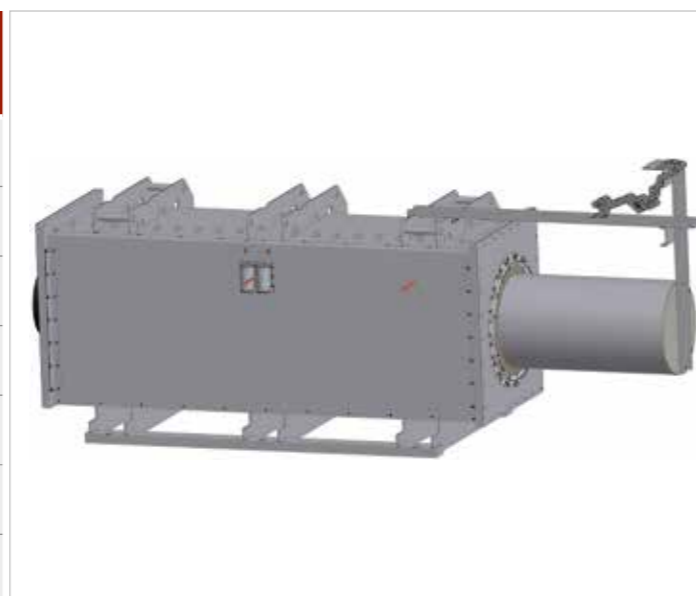

2.04 Integrated package solutions

KÖSTER does more

A cable winch is often one an integral component of an overall requirement.

This means, on the one hand to correctly specify the requirements placed on the winch subsequently and, on the other hand (and above all), to make out the entire project completely in which the winch is integrated.

KÖSTER has developed great skill for the development of integrated package solutions over several years of experience and established this with the implementation of various projects in different fields under extremely difficult conditions at times.

Whether in hydro-electric power plants, industrial chimneys or the steel industry, the complexity of developing and constructing winch equipment proves itself particularly impressive and transparent when it comes to transporting people.

In this field, construction also includes moving loads of various specific weights, the baskets suitable for transporting people, the associated crossbeams as well as the relevant failsafe and emergency controller.



Passenger winch Type E 630 P - The crossbeam supports the winch to which the work platform and personal cage is fixed for moving into the shaft, and the scope of supply in this reference project also included a failsafe PLC and emergency controller (hydro-electric power station at Palagnedra, Switzerland)

| | | |
|-------------|-----------------------------------|---------|
| 3.01 | Standard range of products | Page 34 |
| 3.02 | Stage and entertainment | Page 40 |
| 3.03 | Maritime and offshore use | Page 42 |



Manual winch WH 10 L -
with automatic mechanical
brake, load up to 1,000 kg

3.0 Manual winches

Made of iron and nodular graphite casting

KÖSTER has been producing manual winches for almost 100 years and continues to carefully manufacture its primary components made of iron and nodular graphite casting in its own, highly-modernised foundry.

This knowledge of manufacturing is rare within the winch market. It has become a unique feature of KÖSTER as well as the guarantee for the excellent hallmark of its manual winches: reliable quality, exceptionally high stability as well as reliability and long service life.

These properties and the fact that advanced development of our winches takes place in a flexible and timely manner in response to the changes in the market have enabled KÖSTER winches to be used in the most diverse sectors.

Standard features

- > Cable fastening by boreholes and two-threaded pins
- > Reliable automatic mechanical brakes or dynamic self-inhibition by worm gears (WH 16 S)
- > Mechanism group **1B_m (M3)**

Additional options

- > Can be supplied with a manual crank with reversible grip
- > Manual crank of the WH 050, WH 1 and WH 3 is fitted with rectangular studs and detachable
- > For additional safety, the WH 3, WH 5, WH 10 or WH 15 with upper cover can be provided
- > WH 2S, WH 5S, WH 7S or WH 16S may also be used as traversing winches for pushing loads
- > Multi-cable operation
- > With extended cable drum - Lx design
- > Customized drum distribution
- > Customized design of the cable fastening (e.g.: separating strip)
- > Designed for passenger transport
- > Designed for public areas (according to BGV C1, cf. page 40)





3.01 Standard range of products

| WH Series |  | Usable cable capacity ¹⁾²⁾ for single-cable operation and non-grooved drum in ... | | | | | | | | | |
|--------------------------------|---|--|----------------------|------------------------|----------------------------|----------------------------|-------------------------|-------------------------|-------------------------|--------------------|--------------------|
| | | Load 1. Cable length kg | Cable diameter mm | 1. Drum layer m | 2 Drum layers m | 3 Drum layers m | 4 Drum layers m | 5 Drum layers m | 6 Drum layers m | 7 Drum layers m | 8 Drum layers m |
| WH 050 |  | 63 | 3 | 2.4 | 6.1 | 10.0 | 14.3 | 18.8 | 23.5 | 28.6 | - |
| WH 1 |  | 125 | 4 | 2.3 | 5.7 | 9.4 | 13.4 | 17.7 | 22.3 | 27.3 | - |
| WH 3L / 3L gr WH 5L / 5L gr |  | 300 500 | 5 6 | 4.8/5.9 5.2/6.2 | 11.4 / 14.0 12.6 / 15.0 | 18.4/22.6 20.6/24.2 | 25.9/- 29.0/33.9 | 33.9/- 37.9/44.0 | 42.2/- 47.3/54.7 | - 57.1/- | - 67.4/- |
| WH 10 L WH 15 L |  | 1.000 1.500 | 9 11 | 6.1 5.4 | 15.3 13.8 | - - | - - | - - | - - | - - | - - |
| WH 2S WH 5S WH 7S |  | 250 500 750 | 5 6 8 | 4.8 7.9 9.2 | 11.3 18.1 21.5 | - 29.1 34.7 | - - 49.0 | - - - | - - - | - - - | - - - |
| WH 16S |  | 1.000 | 8 | 6.6 | 16.4 | 27.1 | 38.6 | - | - | - | - |
| WH 3 / 3 gr WH 5 / 5 gr |  | 300 500 | 5 6 | 4.8 / 5.9 5.2 / 6.2 | 11.4 / 14.0 12.6 / 15.0 | 18.4 / 22.6 20.6 / 24.2 | 25.9 / - 29.0 / 33.9 | 33.9 / - 37.9 / 44.0 | 42.2 / - 47.3 / 54.7 | - 57.1 / - | - 67.4 / - |
| WH 10 WH 15 |  | 1.000 1.500 | 9 11 | 6.1 5.4 | 15.3 13.8 | - - | - - | - - | - - | - - | - - |

| For dual-cable operation and grooved drum per cable | | | Manual operation | | Specifications of gearbox and brakes | | | | |
|---|---|--|--|--|--------------------------------------|---------------------------|--------------|-----------------------|--------------------|
| Wire cable diameter mm | One Cable layer Figures 3.1-1, 3.1-2, 3.1-5 | Two drum layers acc. to Figures 3.1-3, 3.1-4 | Load elevation per crank revo- lution in 1. Cable layer mm | Crank pressure for max. load in the 1st cable layer kg | Brake type | Release loads by | Gearbox type | Gearbox ratio i | Net weight kg |
| - | - | - | 204 | 10.0 | Automatic mech. brake | Turn back the crank | Direct | 1 | 6.5 |
| - | - | - | 210 | 14.9 | Automatic mech. brake | Turn back the crank | Direct | 1 | 9 |
| 4 5 | 1.8 / 2.2 1.7 / 2.0 | 4.8 / 6.0 5.5 / 6.5 | 76 / 95 69 / 81 | 10.3 / 12.8 15.4 / 18.1 | Automatic mech. brake | Turn back the crank | Gear drive | 5.15 7.15 | 27 / 32 42 / 44 |
| 6 8 | 3.0 2.2 | 5.4 7.0 | 36 30 | 16.4 20.3 | Automatic mech. brake | Turn back the crank | Gear drive | 18 22.5 | 80 100 |
| 4 5 6 | 2.6 4.1 5.1 | Drum not grooved | 20 26 20 | 9.2 14.5 16.0 | Automatic mech. brake | Turn back the crank | Worm drive | 16 16 25 | 12.5 21 42 |
| 6 | 3.0 | - | 14.5 | 18.0 | Self- inhibiting | Turn back the crank | Worm drive | - | 72 |
| 4 5 | 1.8 / 2.2 1.7 / 2.0 | 4.8 / 6.0 5.5 / 6.5 | 76 / 95 69 / 81 | 10.3 / 12.8 15.4 / 18.1 | Brake controller | Turn back the crank | Gear drive | 5.15 7.15 | 34 / 39 50 / 52 |
| 6 8 | 3.0 2.2 | 5.4 7.0 | 36 30 | 16.4 20.3 | Brake controller | Turn back the crank | Gear drive | 18 22.5 | 87 110 |

1) While specifying the cable capacity, two spare loops have already been deducted. The maximum cable capacity is calculated considering 1.5 x cable diameter as the flanged pulley projection.
2) Dual-cable operation even with non-grooved drum is possible, wire cable capacity is then 15-20 % more. Wire cable must be wound up uniformly on a grooved drum. If winding is necessary in the 2nd drum layer, provide drum grooves in accordance with Figures 3.1-3, 3.1-4.

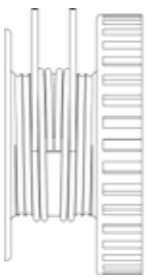
Drum grooving / Cable winding for dual cable operation

| WH 3 / WH 5 | WH 10 / WH 15 | WH 3 / WH 5 | WH 10 / WH 15 | WH 3 / WH 5 / WH 10 / WH 15 |
|---|---|--|--|---|
|  |  |  |  |  |
| Figure 3.1-1 | Figure 3.1-2 | Figure 3.1-3 | Figure 3.1-4 | Figure 3.1-5 |
| one Cable layer | | running apart | | running together, one Cable layer |
| Both sides are fastened to the same drum flanged wheel and are wound up from there in parallel in the direction of other drum flanged wheel. | | The cable is fastened at the centre of the drum and, from there, both cable strands are wound up by both drum flanged wheels. | | Cable winding is possibly only from the flanged wheel to the centre. |
| Only one single cable layer is possible for winding the cable up on this drum. Drum grooving as illustrated in Figures 3.1 and 3.1-4 is preferred dual-layer and multiple-layer cables. | | Both cable strands run from the drum flanged wheel to the centre of the drum flanged wheel and back in the second cable layer. | | |

WH Series - Manual winches by size

Load capacity 63 - 125 kg

| Type WH050 | | | | Type WH1 | | | | | | | | | | | | | | | |
|---------------|-------------|-------------------------|-----|----------|-------|----|-----|-----|----|-----|-----|----|-------|-----|-------|----|-------|--|--|
| Drum diameter | Drum length | Flanged pulley diameter | A | B | C | D | E | F | G | H | K | L | M | N | O | P | | | |
| WH 050 | 62 | 50 | 113 | 11 | 80 | 62 | 142 | 170 | 25 | 100 | 142 | 16 | 106.5 | 260 | 108.5 | 12 | 227 | | |
| WH 1 | 63 | 58 | 130 | 14 | 102.5 | 51 | 154 | 220 | 25 | 178 | 218 | 20 | 140 | 350 | 108.5 | 12 | 260.5 | | |

Load 300 - 1,500 kg with automatic mechanical brake

| Type WH3L (gr) - WH5L (gr) | | | | | | Type WH10L - WH15L | | | | | | | | | | |
|----------------------------|-------------|-------------------------|-----|-----|-----|--------------------|----|-----|-----|-----|-----|-----|-----|-----|-----|--|
| Drum diameter | Drum length | Flanged pulley diameter | A | B | C | D | E | F | G | H | K | L | M | N | | |
| WH 3 L | 120 | 79 | 210 | 265 | 313 | 5 | 15 | 222 | 353 | 494 | 236 | 445 | 25 | 300 | - | |
| WH 3 L gr | 150 | 79 | 210 | 265 | 313 | 5 | 15 | 222 | 353 | 494 | 236 | 445 | 25 | 300 | - | |
| WH 5 L | 150 | 86 | 294 | 335 | 387 | 6 | 19 | 266 | 437 | 505 | 236 | 445 | 25 | 311 | - | |
| WH 5 L gr | 178 | 86 | 294 | 335 | 387 | 6 | 19 | 266 | 437 | 505 | 236 | 445 | 25 | 311 | - | |
| WH 10 L | 200 | 117 | 275 | 345 | 400 | 9 | 20 | 447 | 630 | 603 | 238 | 440 | 138 | 30 | 379 | |
| WH 15 L | 205 | 125 | 290 | 396 | 446 | 11 | 20 | 553 | 695 | 628 | 238 | 440 | 138 | 30 | 402 | |

Load capacity 250 - 1,000 kg

| Type WH2S - WH7S | | | | | | | | | | | Type WH16S | | | | | | | |
|------------------|-------------|-------------------------|-----|-----|-----|----|-----|-----|-----|-----|------------|-----|-----|-----|-----|----|-----|--|
| Drum diameter | Drum length | Flanged pulley diameter | A | B | C | D | E | F | G | H | K | L | M | N | O | P | | |
| WH 2 S | 96 | 94 | 135 | 137 | 219 | 12 | 205 | 237 | 5 | 120 | 79 | 313 | 108 | 295 | 96 | 45 | 18 | |
| WH 5 S | 125 | 138 | 182 | 190 | 282 | 14 | 250 | 290 | 6 | 150 | 101 | 250 | 238 | 440 | 112 | 46 | 22 | |
| WH 7 S | 150 | 182 | 240 | 243 | 350 | 20 | 330 | 390 | 8 | 205 | 146 | 349 | 238 | 440 | 349 | 81 | 160 | |
| WH 16 S | 175 | 155 | 280 | 354 | 390 | 17 | 230 | 300 | 376 | 172 | 400 | 623 | 222 | 440 | 231 | - | - | |

Load capacity 300-1,500 kg with braking force controller

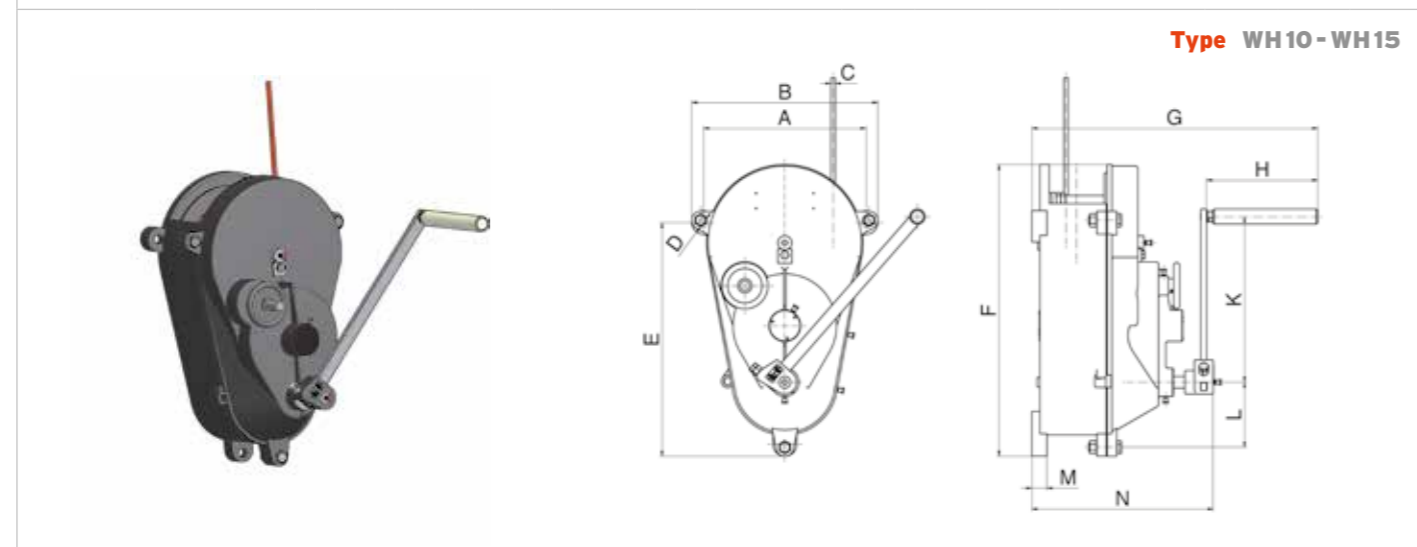
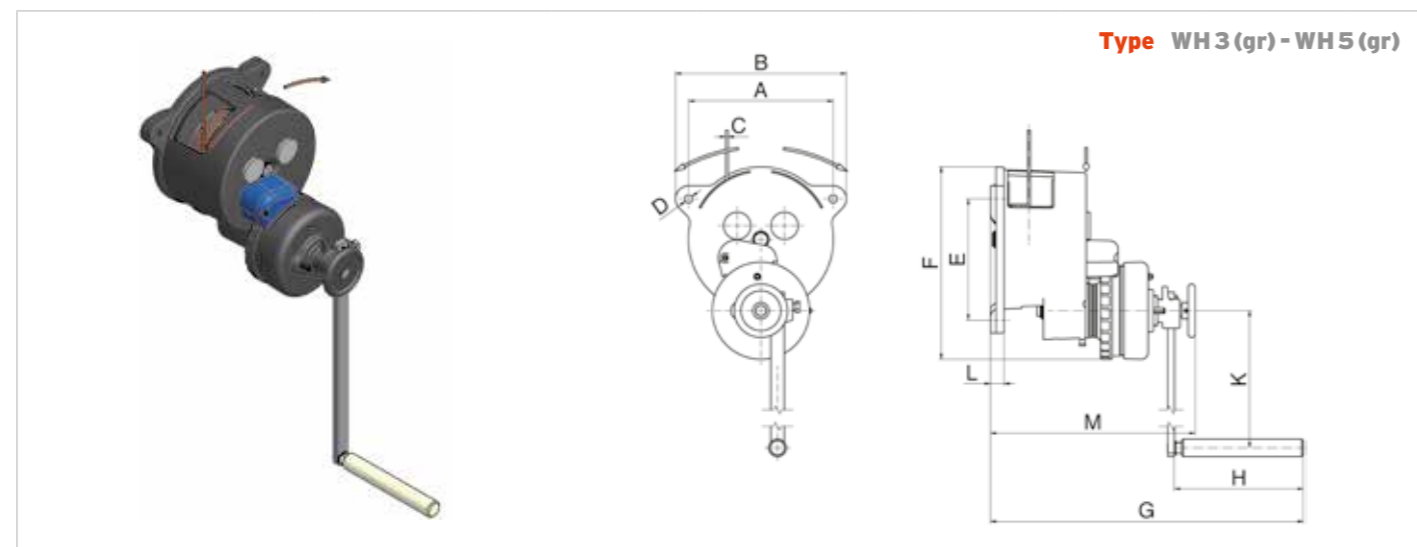

| | Drum diameter | Drum length | Flanged wheel diameter | A | B | C | D | E | F | G | H | K | L | M | N |
|---------|---------------|-------------|------------------------|-----|-----|----|------|-----|-----|-----|-----|-----|-----|-----|-----|
| WH 3 | 120 | 79 | 210 | 265 | 313 | 5 | 15 | 221 | 353 | 573 | 236 | 446 | 25 | 375 | - |
| WH 3 gr | 150 | 79 | 210 | 265 | 313 | 5 | 15 | 221 | 353 | 573 | 236 | 446 | 25 | 375 | - |
| WH 5 | 150 | 86 | 294 | 335 | 387 | 6 | 19 | 266 | 437 | 584 | 236 | 446 | 25 | 386 | - |
| WH 5 gr | 178 | 86 | 294 | 335 | 387 | 6 | 19 | 266 | 437 | 584 | 236 | 446 | 25 | 386 | - |
| WH 10 | 200 | 117 | 275 | 345 | 395 | 9 | 20.5 | 496 | 619 | 607 | 236 | 352 | 138 | 32 | 385 |
| WH 15 | 205 | 125 | 290 | 375 | 447 | 11 | 20 | 530 | 695 | 628 | 238 | 440 | 138 | 30 | 402 |



3.02 Stage and entertainment

The special requirements for winches used where people work or stay under suspended loads have been explained in Section 2.01 as well as the skills that KÖSTER has demonstrably acquired in this segment.

KÖSTER has also targeted a proven standard product line in the construction of manual winches, which have been adapted to meet the safety provisions that apply to public areas where people remain under suspended loads (theatres, studios, malls etc.).

Special features

- > Two automatic mechanical brakes operate independently, and thus, loads are held safely and securely at every position
- > Cable is wound up in a single layer
- > Equipped with cable pressure roller

| Winches according to BGV C1 | | | | | | | |
|-----------------------------|------|-------------------|----------------|------------------------------|---------------------------------------|---|--|
| | Load | Load el, per rev. | Crank pressure | Cable diameter ¹⁾ | Cable hoisting distance ²⁾ | Remarks | |
| | kg | mm | kg | mm | m | | |
| WH 5 LB gr - 100 | 100 | 81 | 18.1 | 4 | 7.7 | Two independent brakes | |
| WH 5 LB gr - 180 | 180 | 81 | 18.1 | 5 | 6.3 | | |
| WH 5 LB gr - 250 | 250 | 81 | 18.1 | 6 | 5.3 | | |
| WH 5 LB gr - 300 | 300 | 81 | 18.1 | 7 | 4.5 | | |
| WH 5 LB gr - 301 | 300 | 81 | 18.1 | 8 | 4 | | |
| WH 2 SB | 250 | 20 | 9.2 | 6 | 3.8 | Drum length, cable hoisting distance, cable diameter and the number of cables can be adapted to the application | |
| WH 5 SB | 450 | 26 | 14.5 | 8 | 5 | | |
| WH 7 SB | 600 | 20 | 16.0 | 9 | 7.5 | | |
| WH 2 SB /Lx | 250 | 20 | 9.2 | | | dynamic self-limiter | |
| WH 5 SB /Lx | 450 | 26 | 14.5 | | | | |
| WH 7 SB /Lx | 600 | 20 | 16.0 | | | | |
| WH 16 SB | 560 | 14,5 | 18,0 | 9 | 7 | Drum length, cable hoisting distance, cable diameter and the number of cables can be adapted to the application | |
| WH 16 SB /Lx | 560 | 14,5 | 18,0 | | | | |

1) The cable diameter is related to low-expansion cables with steel inserts according to DIN 3069.
2) While specifying the cable capacity, two spare loops have already been deducted.

Drill operated winch

These manual winches have a dynamic, self-limiting worm-gear drive and an additional manual disc brake, which also enhances safety.

If the operator releases the brake, it will hold and trigger the torque limiter of the battery-operated drill. In the process, the safety standard for this winch at KÖSTER is **beyond** the provisions of BGV C1.

This winch can be supplied in different lengths depending on the cable capacity.

| Drill operated winch | | H 100 B | H 200 B | H 250 B |
|---------------------------|--------------------|------------------------|---------|---------|
| Load acc. to BGV C1 | kg | 100 | 200 | 250 |
| Cable hoisting distance | m | variable | | 6 |
| Cable speed ¹⁾ | m/min ¹ | max. 5 | | 3 |
| Number of cables | - | variable | | 4 |
| Cable diameter | mm | 4-6 | | 5 |
| Weight | kg | depending on execution | | 80 |
| Driving mechanism group | - | 2 _m (M5) | | |
| Cable Layers | - | 1 | | |

1) For screwdriver speed of 1,300 rpm, higher speeds are not permissible



At left:
The KÖSTER drill operated winch move an advertising banner as shown here in the main railway station in Munich with a weight of up to 200 kg.

At right:
Concealed behind a cover made of stainless steel, it merges with any environment in a subtle and attractive manner.



3.03 Maritime and offshore use

Made of stainless steel

Cable winches are also integrated in harbour cranes, ship cranes and offshore cranes and are sometimes exposed to extreme weather conditions. KÖSTER is one of the leading producers of winches and winch systems for maritime use worldwide.

Winches conforming to the standards of this special segment are characterized by their low self-weight, low crank operating forces and an almost noise-free automatic mechanical brake. The selection of the most appropriate material is decisive for a reliable operation.

We continuously develop our winches and winch systems for maritime use and optimize their reliable performance.

The „Germanische Lloyd“ has accepted the KÖSTER winch in stainless steel design.

| Winches made of stainless steel | | H 300 | H 301 | H 400 |
|---|----|-----------------------|-----------------------|-----------------------|
| Load of the 1st cable layer | kg | 300 | 300 | 400 |
| Cable diameter | mm | 5 | 6 | 6 |
| Maximum cable capacity | m | 50 | 30 | 15 |
| Number of cable layers | - | 7 | 3 | 3 |
| Load of last cable layer | kg | 185 | 300 | 327 |
| Driving mechanism group | - | 1 E _m (M1) | 1 B _m (M3) | 1 E _m (M1) |
| Drum diameter | mm | 88.1 | 267 | 88.1 |
| Flanged wheel diameter | mm | 160 | 360 | 160 |
| Drum length | mm | 110 | 110 | 110 |
| Self-weight (without cable) | kg | 16 | 53 | 24 |
| Load elevation per crank revolution | mm | 63 | 57 | 51 |
| Crank force at rated load | N | 138 | 118 | 168 |
| Crank force when the load is released | N | 20 | 15 | 20 |
| Number of crank revolutions for maximum elevation | - | 635 | 789 | 294 |

| H 300 | H 301 | H 400 |
|-------|-------|-------|
| | | |
| | | |
| | | |
| | | |

| | | |
|-------------|--------------------------|---------|
| 4.01 | Pulleys | Page 45 |
| 4.02 | Other accessories | Page 51 |

Pulley WZ 20-24 -
with pulley bracket
and friction bearing

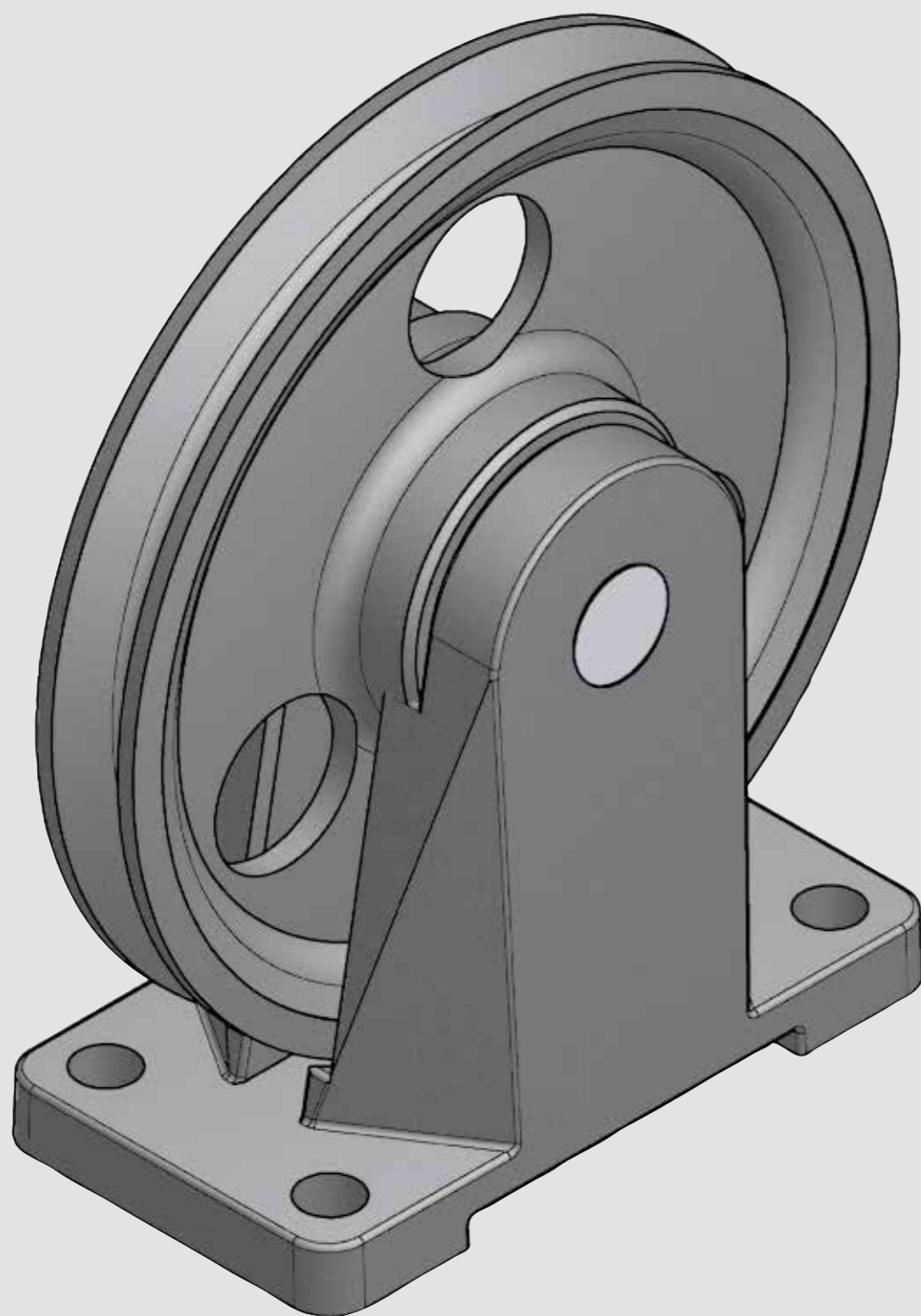

4.0 Accessories made from our own metal castings

As a complete system supplier, KÖSTER manufactures everything under a single roof, from the smallest individual component to total integrated solutions.

The starting point for this is always the single pulley. We manufacture these and other accessories for our cable winches in our highly modern foundry with a high level of precision.

4.01 Pulleys

Pulleys without pulley bracket and bearing

Simple, low-cost design, only for manual winches; cable groove: cast groove profile, bearing without bearing bush; pulley material EN-GJL-250 (GG 25)

| Without pulley bracket and bearing | WN 100 a-1 | WN 100 a-2 | WN 100 a-3 |
|------------------------------------|------------|------------|------------|
| for hoisting cable (kg) | 50-125 | 250-500 | 500-1000 |
| specified cable diameter (mm) | 3-6 | 6-8 | 8-12 |
| Ø a | 140 | 200 | 250 |
| Ø b | 100 | 140 | 185 |
| c | 35 | 35 | 35 |
| d | 12 | 16 | 22 |
| e | 26 | 40 | 42 |
| f | 35 | 45 | 50 |

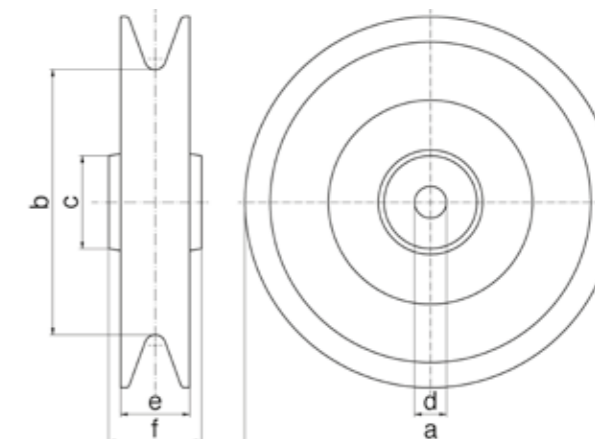

Pulleys without pulley bracket, with friction bearing

Maintenance-free design for manual and motorized operation, pulley diameter equal to 21 to 40 times of the wire cable diameter, related to the centre of the cable.

Dimensions for
 > Manual operation of the mechanism group 1B_m (M3) acc. to DIN 15020 sheet 1
 > Motor operation 1A_m (M4) to 2_m (M5) depending on the use intended

Cable groove profile reversed, bearing for the WZ10-WZ14 pulleys through self-lubricating bearing with WZ15/WZ16 grease chamber, WZ 15 / WZ 16 through bronze bearing with lubricant pockets, pulley material EN-GJL-250(GG25)

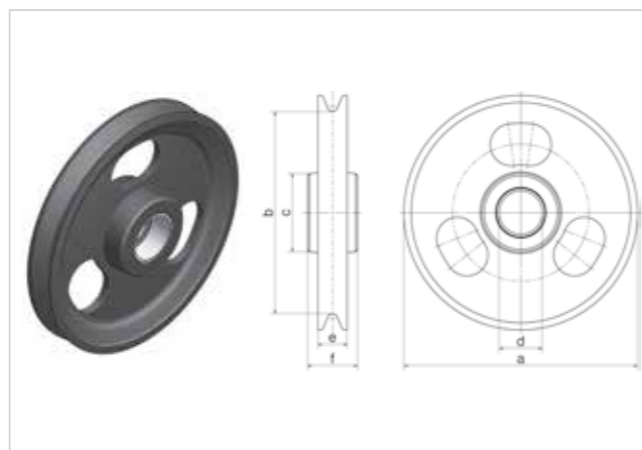

| Without pulley bracket, with friction bearing | | | | | | | | | | |
|---|-------|---------|-------|-------|---------|-------|---------|-------|-------|-------|
| | WZ 10 | WZ 10.5 | WZ 11 | WZ 12 | WZ 12.5 | WZ 13 | WZ 13.5 | WZ 14 | WZ 15 | WZ 16 |
| max. cable load for manual op. (kg) | 100 | 150 | 250 | 500 | 750 | 1000 | 1500 | 2000 | 3200 | 5000 |
| max. cable load for motor op. with 180° cable deflection (kg) | 50 | 75 | 125 | 250 | 375 | 500 | 750 | 1000 | 1600 | 2500 |
| max. cable load for motor op. with 90° cable deflection (kg) | 75 | 100 | 180 | 320 | 500 | 630 | 1000 | 1250 | 2000 | 3200 |
| specified cable diameter (mm) | 2-3 | 3-4 | 4-5 | 5-6 | 6-8 | 8-10 | 10-12 | 12-14 | 14-16 | 16-20 |
| ∅ a | 60 | 90 | 120 | 150 | 190 | 235 | 280 | 325 | 375 | 470 |
| ∅ b | 48 | 72 | 100 | 125 | 160 | 200 | 240 | 280 | 320 | 400 |
| ∅ c | 22 | 32 | 35 | 46 | 62 | 78 | 92 | 108 | 120 | 140 |
| ∅ d | 8 G7 | 14 G7 | 14 G7 | 22 G7 | 32 G7 | 40 G7 | 50 G7 | 60 H7 | 70 H9 | 70 H9 |
| e | 13 | 15 | 18 | 22 | 27 | 32 | 36 | 41 | 48 | 58 |
| f | 24 | 32 | 35 | 40 | 42 | 50 | 62 | 70 | 85 | 90 |

Pulleys without pulley bracket, with grooved ball bearings

Maintenance-free design for motorized operation, cable groove profile reversed, bearing of the pulleys with two grooved ball bearings

Normal tolerance according to DIN 620) and seals, pulley material EN-GJL-250 (GG 25)

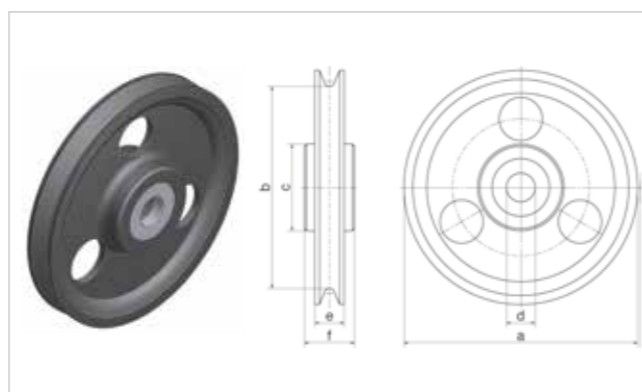

| Without pulley bracket, with grooved ball bearing | | | | | | | | | |
|---|---------|---------|-----------|---------|-----------|---------|---------|---------|--|
| | WZ 11 K | WZ 12 K | WZ 12.5 K | WZ 13 K | WZ 13.5 K | WZ 14 K | WZ 15 K | WZ 16 K | |
| max. cable load for motor op. with 180° cable deflection (kg) | 125 | 250 | 500 | 500 | 750 | 1000 | 1600 | 2500 | |
| max. cable load for motor op. with 90° cable deflection (kg) | 180 | 320 | 375 | 630 | 1000 | 1250 | 2000 | 3200 | |
| specified cable diameter (mm) | 4-5 | 5-6 | 6-8 | 8-10 | 10-12 | 12-14 | 14-16 | 16-20 | |
| ∅ a | 120 | 150 | 190 | 235 | 280 | 325 | 375 | 470 | |
| ∅ b | 100 | 125 | 160 | 200 | 240 | 280 | 320 | 400 | |
| ∅ c | 55 | 60 | 74 | 85 | 100 | 120 | 150 | 160 | |
| ∅ d | 17 | 20 | 25 | 30 | 35 | 40 | 60 | 60 | |
| e | 18 | 22 | 27 | 32 | 36 | 41 | 50 | 58 | |
| f | 35 | 41.5 | 34 | 37 | 62 | 70 | 48 | 90 | |

Pulley with pulley bracket, without bearing

Simple, low-cost design, only for manual winches; Cable groove: cast groove profile

Bearing without bearing bush; pulley material EN-GJL-250 (GG 25)

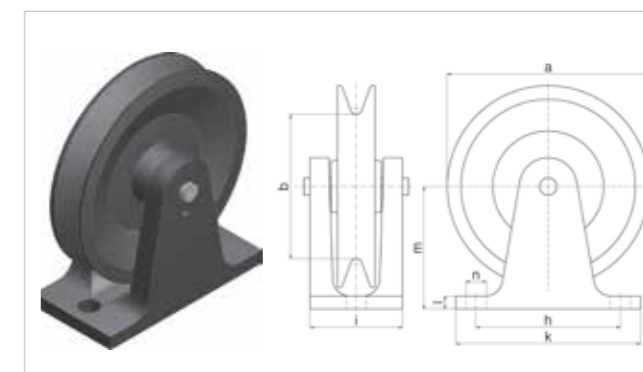

| With pulley bracket, without bearing | | | |
|--------------------------------------|------------|------------|------------|
| | WZ 100 a-1 | WZ 100 a-2 | WZ 100 a-3 |
| for cable hoist (kg) | 50 - 125 | 250 - 500 | 500 - 1000 |
| specified cable diameter (mm) | 3 - 6 | 6 - 8 | 8 - 12 |
| ∅ a | 140 | 200 | 250 |
| ∅ b | 100 | 140 | 185 |
| h | 100 | 100 | 210 |
| i | 64 | 78* | 84* |
| k | 128 | 140 | 245 |
| l | 9 | 13 | 17 |
| m | 85 | 120 | 145 |
| ∅ n | 14 | 14 | 22 |

*Lubrication: Oil hole Stauffer bush, total width = i + 40mm

Pulley with pulley bracket and friction bearing

Maintenance-free design for manual and motor operation

The design of the pulleys is equivalent to WZ10-WZ16; pulley bracket shows that cable slippage or binding for cable guides between the pulley and the bearing is not possible for slack cable. Downward horizontal cable feeds are possible, even with standing pulleys. Models WZ20 to WZ24 are pulleys and pulley brackets made of material EN-GJL-250(GG25), WZ25 & WZ26 pulleys made of material EN-GJL-250(GG25), pulley brackets made of steel. **Special designs include pulleys with protective clips**

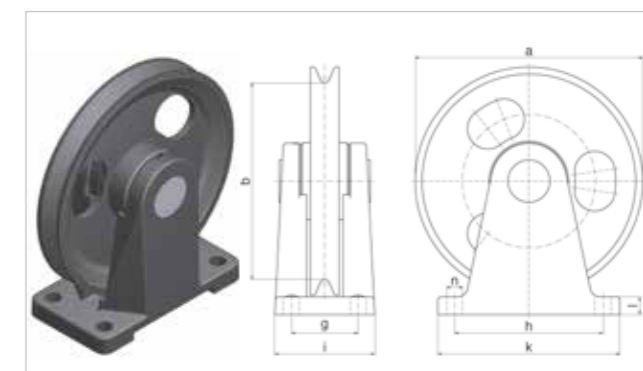

| With pulley bracket, with friction bearing | | | | | | | | | | |
|--|-------|--------|-------|-------|---------|-------|---------|-------|-------|-------|
| | WZ 20 | WZ20.5 | WZ 21 | WZ 22 | WZ 22.5 | WZ 23 | WZ 23.5 | WZ 24 | WZ 25 | WZ 26 |
| max. cable load for manual op. (kg) | 100 | 150 | 250 | 500 | 750 | 1000 | 1500 | 2000 | 3200 | 5000 |
| kg for motor operation with 180° cable deflection (kg) | 50 | 75 | 125 | 250 | 375 | 500 | 750 | 1000 | 1600 | 2500 |
| kg for motor operation with 90° cable deflection (kg) | 75 | 100 | 180 | 320 | 500 | 630 | 1000 | 1250 | 2000 | 3200 |
| specified cable diameter (mm) | 2-3 | 3-4 | 4-5 | 5-6 | 6-8 | 8-10 | 10-12 | 12-14 | 14-16 | 16-20 |
| ∅ a | 60 | 90 | 120 | 150 | 190 | 235 | 280 | 325 | 375 | 470 |
| ∅ b | 48 | 72 | 100 | 125 | 160 | 200 | 240 | 280 | 320 | 400 |
| g | 30 | 44 | 50 | 55 | 65 | 70 | 80 | 95 | 95 | 125 |
| h | 42 | 62 | 70 | 88 | 120 | 150 | 180 | 212 | 240 | 310 |
| i | 44 | 66 | 74 | 82 | 95 | 108 | 120 | 143 | 185 | 225 |
| k | 56 | 84 | 92 | 115 | 150 | 187 | 220 | 260 | 300 | 380 |
| l | 8 | 10 | 13 | 15 | 17 | 20 | 22 | 25 | 22 | 30 |
| m | 40 | 57 | 75 | 92 | 115 | 138 | 164 | 190 | 212 | 270 |
| ∅ n | 7 | 9 | 11.5 | 11.5 | 14 | 18 | 18 | 23 | 26 | 33 |

Pulleys with pulley bracket and grooved ball bearing

Pulley design like that of WZ 11 K - WZ 16 K

Pulley material EN-GJL-250 (GG 25) or steel, optionally galvanized steel

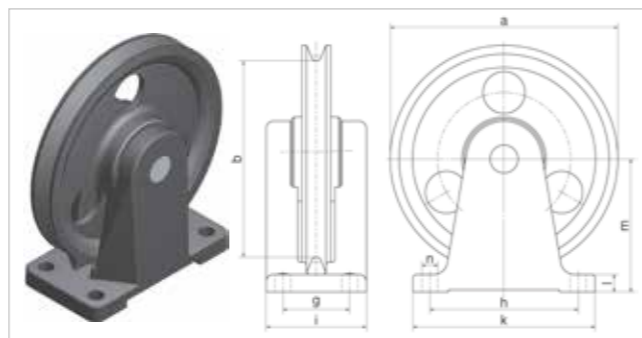

| With pulley bracket, with grooved ball bearing | | | | | | | | |
|---|---------|---------|-----------|---------|-----------|---------|---------|------------|
| | WZ 21 K | WZ 22 K | WZ 22.5 K | WZ 23 K | WZ 23.5 K | WZ 24 K | WZ 25 K | WZ 26 K |
| max. cable load for motor op. with 180° cable deflection (kg) | 125 | 250 | 375 | 500 | 750 | 1000 | 1600 | 2500 |
| max. cable load for motor op. with 90° cable deflection (kg) | 180 | 320 | 500 | 630 | 1000 | 1250 | 2000 | 3200 |
| specified cable diameter (mm) | 4-5 | 5-6 | 6-8 | 8-10 | 10-12 | 12-14 | 14-16 | 16-20 |
| ∅ a | 120 | 150 | 190 | 235 | 280 | 325 | 375 | on request |
| ∅ b | 100 | 125 | 160 | 200 | 240 | 280 | 320 | |
| g | 50 | 55 | 65 | 70 | 80 | 95 | 95 | |
| h | 68 | 88 | 120 | 150 | 180 | 212 | 240 | |
| i | 74 | 82 | 95 | 108 | 120 | 143 | 185 | |
| k | 92 | 115 | 150 | 187 | 220 | 260 | 300 | |
| l | 13 | 15 | 17 | 20 | 22 | 25 | 22 | |
| m | 75 | 92 | 115 | 138 | 164 | 190 | 212 | |
| ∅ n | 11.5 | 11.5 | 14 | 18 | 18 | 23 | 26 | |

Fixed dual cable pulley with pulley bracket and friction bearing

Pulley design like that of WZ 11 - WZ 14, pulley bracket made of welded steel

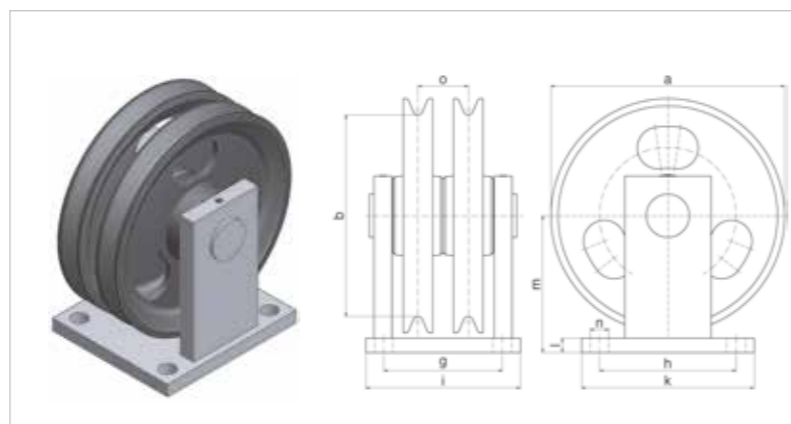

| Dual cable pulley, fixed | | | | | | |
|--|-------|-------|---------|-------|---------|-------|
| | WZ 51 | WZ 52 | WZ 52.5 | WZ 53 | WZ 53.5 | WZ 54 |
| max. cable load per pulley for manual op. (kg) | 250 | 500 | 750 | 1000 | 1500 | 2000 |
| max. cable load per pulley for motor op. (kg) | 125 | 250 | 375 | 500 | 750 | 1000 |
| specified cable diameter (mm) | 4-5 | 5-6 | 6-8 | 8-10 | 10-12 | 12-14 |
| ∅ a | 120 | 150 | 190 | 235 | 280 | 325 |
| ∅ b | 100 | 125 | 160 | 200 | 240 | 280 |
| g | 100 | 96 | 95 | 110 | 130 | 165 |
| h | 75 | 88 | 110 | 140 | 150 | 190 |
| i | 120 | 122 | 125 | 160 | 180 | 215 |
| k | 95 | 115 | 140 | 190 | 200 | 240 |
| l | 10 | 12 | 12 | 15 | 16 | 20 |
| m | 72 | 89 | 110 | 135 | 159 | 190 |
| ∅ n | 11.5 | 11.5 | 14 | 18 | 22 | 26 |
| o | 49.5 | 40 | 42 | 50 | 62 | 70 |

Swivel-type dual cable pulleys with pulley bracket, without friction bearing

Simple, low-cost design, only for manual winches.

Cable groove: cast groove profile, bearing without bearing bush, pulley material EN-GJL-250 (GG 25)

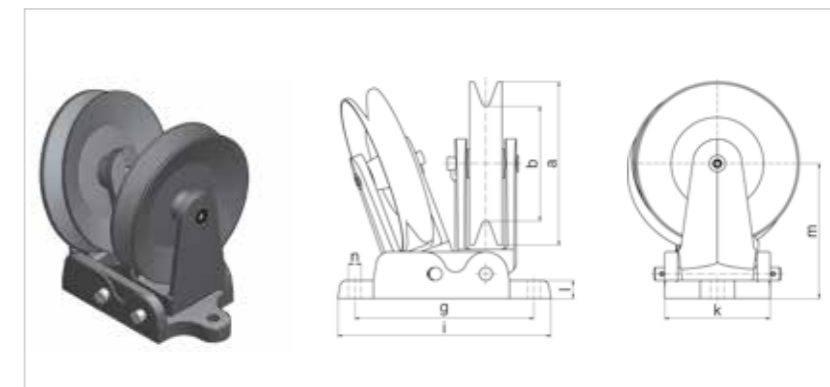

| Dual cable pulley, swivel-type | WZ 105-1 | WZ 105-2 |
|--|----------|----------|
| max. cable load per pulley with manual operation at 180° cable deflection (kg) | 500 | 750 |
| specified cable diameter (mm) | up 8 | up 12 |
| ∅ a | 200 | 250 |
| ∅ b | 140 | 185 |
| g | 220 | 250 |
| i | 262 | 310 |
| k | 129 | 158 |
| l | 22 | 25 |
| m | 165 | 190 |
| ∅ n | 16 | 22 |

Swivel-type pulleys with pulley bracket and friction bearing

Dimensions for

- > Manual operation of the mechanism group 1B_m (M3) acc. to DIN 15020 sheet 1
- > Motor operation 1 A_m (M4) or 2_m (M5) depending on the use

Pulley diameter = 21 - 40 times cable diameter (related to the centre of the cable); bearing: Pulley bracket: maintenance-free self-lubricating bearing; pulley material EN-GJL-250 (GG 25), fastening plate and pulley holder made of steel

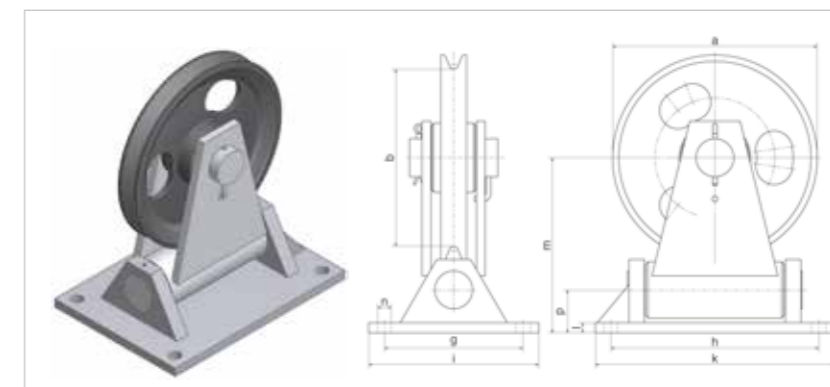

| Swivel-type pulley | WZ 31 | WZ 32 | WZ 32.5 | WZ 33 | WZ 33.5 | WZ 34 |
|-------------------------------------|-------|-------|---------|-------|---------|-------|
| max. cable load for manual op. (kg) | 250 | 500 | 750 | 1000 | 1500 | 2000 |
| max. cable load for motor op. (kg) | 125 | 250 | 375 | 500 | 750 | 1000 |
| specified cable diameter (mm) | 4-5 | 5-6 | 6-8 | 8-10 | 10-12 | 12-14 |
| ∅ a | 120 | 150 | 190 | 235 | 280 | 325 |
| ∅ b | 100 | 125 | 160 | 200 | 240 | 280 |
| g | 100 | 140 | 140 | 160 | 180 | 220 |
| h | 130 | 200 | 210 | 260 | 310 | 330 |
| i | 120 | 170 | 170 | 200 | 220 | 270 |
| k | 150 | 230 | 240 | 300 | 350 | 380 |
| l | 6 | 8 | 10 | 12 | 14 | 16 |
| m | 112 | 142 | 165 | 199 | 239 | 277 |
| ∅ n | 11.5 | 11.5 | 14 | 18 | 18 | 22 |
| P | 32 | 45 | 47 | 59 | 66 | 68 |

Swivel-type dual-cable pulleys with pulley bracket and friction bearing

Dimensions for

- > Manual operation of the mechanism group 1B_m (M3) acc. to DIN 15020 sheet 1
- > Motorized operation 1 A_m (M4) or 2_m (M5) depending on the area of application

Pulley diameter = 21 - 40 times cable diameter (relative to centre of the cable);
 Bearing: pulley bracket: maintenance-free self-lubricating bearing;
 Pulley material EN-GJL-250 (GG 25), fastening plate and pulley holder made of steel

| Dual-cable pulley, swivel-type | WZ 41 | WZ 42 | WZ 42.5 | WZ 43 | WZ 43.5 | WZ 44 |
|--|-------|-------|---------|-------|---------|-------|
| max. cable load with manual operation (kg) | 250 | 500 | 750 | 1000 | 1500 | 2000 |
| max. cable load with motor operation (kg) | 125 | 250 | 375 | 500 | 750 | 1000 |
| specified cable diameter (mm) | 4-5 | 5-6 | 6-8 | 8-10 | 10-12 | 12-14 |
| ∅ a | 120 | 150 | 190 | 235 | 280 | 325 |
| ∅ b | 100 | 125 | 160 | 200 | 240 | 280 |
| g | 85 | 107.5 | 115 | 135 | 155 | 185 |
| h | 130 | 200 | 210 | 260 | 310 | 330 |
| i | 190 | 245 | 260 | 310 | 350 | 420 |
| k | 150 | 230 | 240 | 300 | 350 | 380 |
| l | 8 | 10 | 12 | 14 | 16 | 20 |
| m | 114 | 144 | 167 | 196 | 241 | 281 |
| ∅ n | 11.5 | 11.5 | 14 | 18 | 22 | 26 |
| o | 65 | 85 | 90 | 110 | 120 | 150 |
| p | 34 | 47 | 49 | 56 | 68 | 72 |

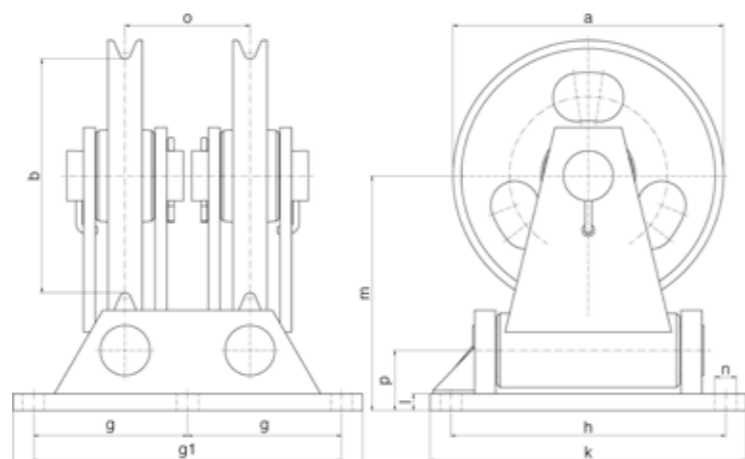

Pulleys with slack cable switch, pulley bracket and friction bearing

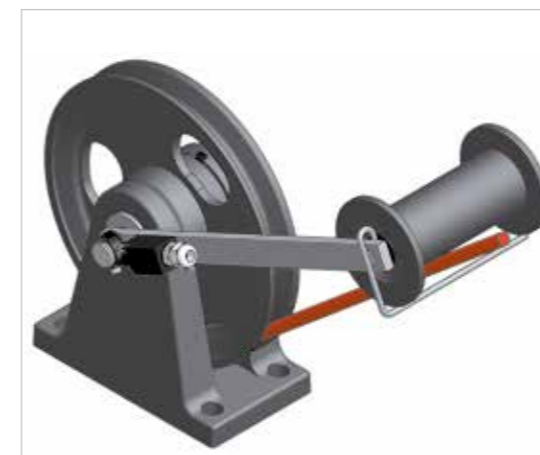

Pulleys with bracket WZ21 - WZ26 can be fitted with slack cable switches, if, for example, they cannot be mounted on the cable winch. Designs for mounting on floors, walls and ceilings are available.

- > Special dimensional drawing on request

Pulleys with limit switch, pulley bracket and friction bearing



End-sensing shut-off switch complete with IP 65 limit switch and adjustable stop mounted on the pulley with pulley bracket

Pulleys with bracket WZ21 - WZ26 or WZ100 a, sizes 1-4 can be equipped with an end-sensing shut-off switch, if, for example, mounting on a hoist limiter is not possible or the necessary cable path cannot be reached. Designs for mounting on floors, walls and ceilings are available.

- > Combination of slack cable and limit switch
- > Special dimensional drawing on request

4.02 Other accessories



Bottom hook blocks, wire cables, wire cable clamps, grommets, shackles, wedge terminating clamps, turnbuckles and eye hooks can be supplied on request and at short notice.

| | | |
|-------------|---------------------------------|---------|
| 5.01 | Delivery & Assembly | Page 53 |
| 5.02 | Maintenance & Repair | Page 54 |
| 5.03 | Spare parts | Page 55 |



5.0 KÖSTER Service Comprehensive

At KÖSTER, we align ourselves with your needs and special requirements. We are pleased to be your partner from the production stage to the supply and right up to mounting ready for operation and beyond this, too.

Our service begins in the planning stage and follows the entire life cycle of our products in your company. The scope of our after-sales service specifies the maintenance contract concluded with you.

It goes without saying that our service also includes supply and proper installation of almost all replacement parts for our cable winches and total integrated solutions.

5.01 Delivery & Assembly

Professional

KÖSTER cable winches are built to be robust and produced with great care. When used properly and as intended a long life and reliable operation are outstanding hallmarks.

Our specially trained and highly experienced employees are very familiar with our high-quality products. This is why we recommend to have your cable winches installed by our specialists on-site until they are ready for operation.

Our installation vehicles have been equipped in such a manner that almost all work that needs to be done in the course of installation - including unscheduled work - has been considered and can be undertaken without delay on-site.

Our technicians are accustomed to working closely and objectively, if required, with other teams or sub-systems at the site of a construction project and to deliver the best quality, notwithstanding difficult conditions prevalent or time pressure.



5.02 Maintenance & Repair

Reliable

Although they also contain highly sensitive components depending on the intended use, KÖSTER winches are highly resistant and do not need maintenance during their service life, even if they are understandably not completely maintenance-free.

Our consolidated maintenance package gives you the certainty that your company is in a position to enjoy fault-free operation, that your employees are relieved of maintenance work and that you have competent support when it comes to complying with safety provisions etc.

KÖSTER places the same emphasis and value on the diligence and quality standard in the execution of maintenance work due as they place on the production of the cable winches. In the course of maintenance, among others, the condition and status of wear and tear of the cables is checked as per schedules. If necessary, wear parts are replaced, switches and screws adjusted or tightened and preserved. Operating materials or consumables are refilled or replaced completely.



5.03 Spare parts

In stock

If components are not used properly, they may be overloaded and get damaged as a result, or even be rendered unusable or they may get destroyed. Moveable parts wear out even under normal and proper operation.

In any case, the relevant components that have become unusable must be replaced. KÖSTER normally produces replacement parts for our cable winches on their own. Components that we cannot manufacture on their own (e.g. electrical parts), are purchased only from specialized suppliers.

KÖSTER thinks and acts in a customer-oriented manner. This is why we keep replacement parts in stock. Accordingly, we supply and repair at short notice and thus prevent longer production downtimes in your company.

Engineering works and Foundry

Pumps

Winches

Swimming pool technology

Castings and machining

Steel hydraulic construction

Friedrich Köster GmbH & Co. KG
Friedrichswerk 1-7
25746 Heide
Germany

T +49 (0)481 797-0
info@koester-heide.de
www.koester-heide.de

